

Open your universe

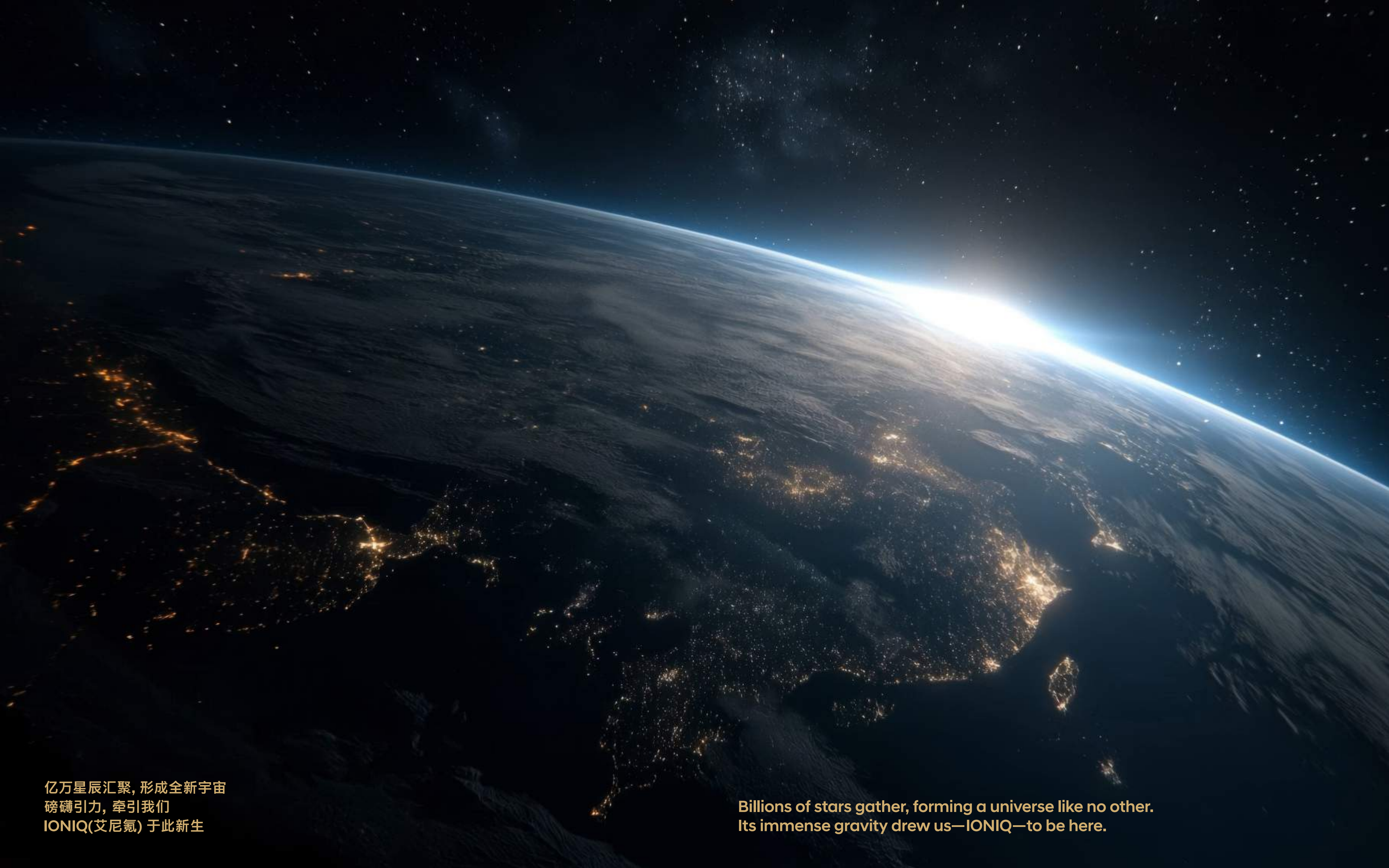

亿万星辰汇聚, 形成全新宇宙
磅礴引力, 牵引我们
IONIQ(艾尼氪) 于此新生

Billions of stars gather, forming a universe like no other.
Its immense gravity drew us—IONIQ—to be here.

IONIQ



IONIQ(艾尼氪) 早已享誉全球，屡获“世界年度车”等至高殊荣
立足久经考验的卓越标准，我们怀抱对中国用户的赤诚与关怀，倾注数载心血
以独特美学重塑经典，以本土科技赋能未来，以深思熟虑的战略携手共进
只为打造中国专属的 IONIQ(艾尼氪)
呈献焕然新生的 IONIQ(艾尼氪)

The IONIQ brand has long proven its excellence, honored by prestigious global awards including the World Car of the Year. Building on these internationally recognized standards, we devoted years to shaping a new IONIQ exclusively for China. Today, we present the reimagined IONIQ—refined through its distinct aesthetic, localized technologies, and thoughtful strategic partnerships—crafted with intention and care for our customers in China.



科技，以人的感受为核心，方能抵达其真正的意义
带着这份对中国的赤诚和信念融入到以人为本的安全创新中
全球权威赞誉实至名归



※ 车型和规格可能因地区而异
※ Model availability and specifications may vary by sales region.

Our commitment to China is rooted in a belief we consider fundamental: technology only reaches its true meaning when it serves humanity. This principle is woven into our safety innovations— designed for people first—and affirmed by the highest recognitions from global authorities.



正是源于这份以人为本的哲学，全新的自由才应运而生
每一条道路都为你敞开，每一个远方都触手可及
打破电动出行边界，在广袤的中国大地上，距离不再是限制
随心而动，直觉而行，尽享自在旅程

And from this human-first philosophy arises a new kind of freedom—one that begins when every road feels open and every destination feels possible. We promise to remove the boundaries that once constrained the electric journey. Across China's immense landscapes, we have worked to ensure that distance is no longer a limitation, allowing you to move freely, intuitively, and without compromise.

A large, faceted, golden-yellow crystal rests on a beach of dark, smooth stones. In the background, the sun is setting over the ocean, creating a warm, golden glow that reflects on the water and the stones. The overall scene is serene and evocative, symbolizing a unique and precious origin.

“专为引领者而生”是我们的信念基石
当万千设计渐趋雷同，我们却始终执着于独树一帜的锋芒
以“惊鸿一瞥”的震撼，开启 IONIQ(艾尼氪) 恢弘叙事的篇章
我们将这一设计哲学称为“启元晶核 (The Origin)”
不循过往，只为成为万象新生的源头

This is our conviction—Lead, don't follow.
Where designs often dissolve into sameness,
we pursued a form that stands unmistakably apart,
defined by its Best in First Impression presence.
We call this 'The Origin'—not to follow what exists,
but to set a new direction.
It marks the beginning of IONIQ's grand narrative.

探究哲学深处是一次回归本质的沉思：
在时代疾驰的炫目进程中，唯有一个问题至关重要——科技，究竟为谁存在？

答案是——你

我们的一切创造，皆始于此，亦终于此
于是，我们奉上 IONIQ(艾尼氪)
——一个完全围绕你的生活而构建并为你照亮未来的宇宙

And at the heart of this philosophy lies a moment of reflection:
in the dazzling speed of progress, only one question truly
mattered—Who is technology for?

Our answer has always been clear: you.

Everything we create begins and ends with that truth.
This is why we present IONIQ as a universe shaped entirely
around your life and oriented toward your future.

The image features a vertical split between two celestial bodies. The left half shows the reddish-orange, cratered surface of Mars, while the right half shows the blue and white swirling clouds of Earth. The text 'Open your universe, IONIQ' is overlaid in a bold, yellow, sans-serif font across the center of the image.

Open your universe, IONIQ

V E N U S
C o n c e p t



‘未知的探索’

太阳系中最耀眼的星辰—金星
它散发着柔和的光芒，内在却蕴藏着强大的能量
尽情去感受未知世界的神秘体验吧

‘Into the Unknown’

Like Venus, the brightest star in our solar system—
it shines with a gentle light, yet holds a powerful energy within.
We present a design that offers an experience as mysterious
as exploring an unknown world.



璀璨金

金星，以光划破长夜，宣告黎明将至
这抹金色，源自金星所象征的突破、探索与荣耀



Radiant Gold

Venus is the first beam of light at the end of the night, a signal before dawn arrives.
This golden hue is derived from the meaning of Venus's spirit of breakthrough, exploration, and glory.

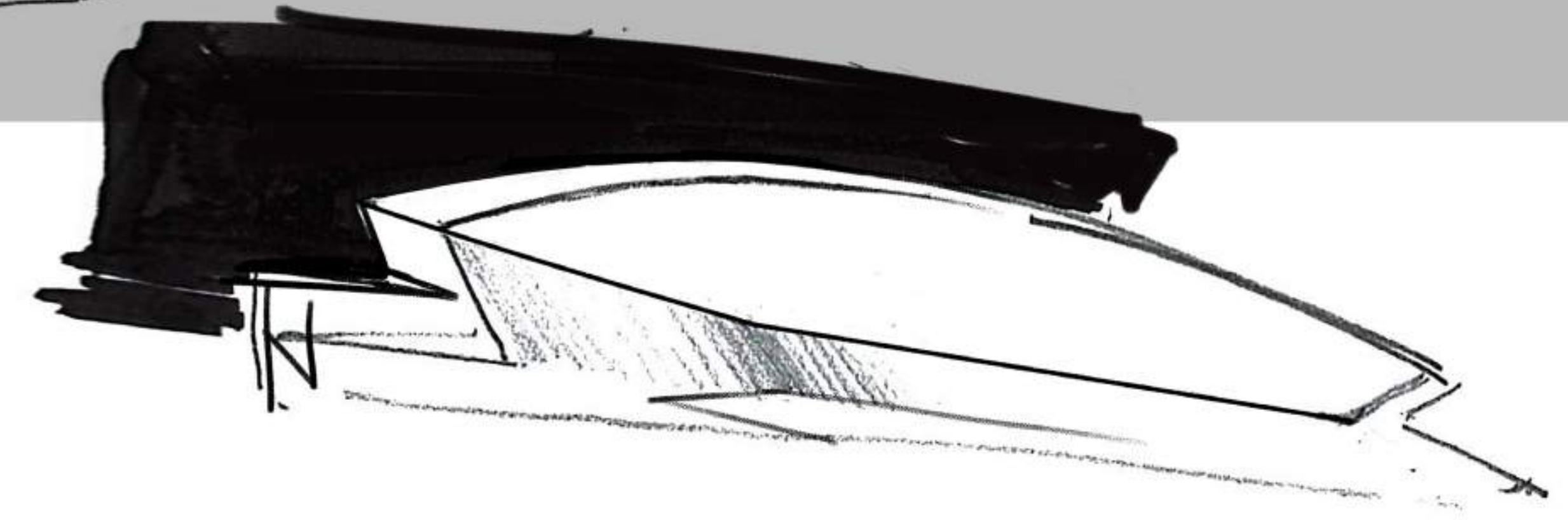
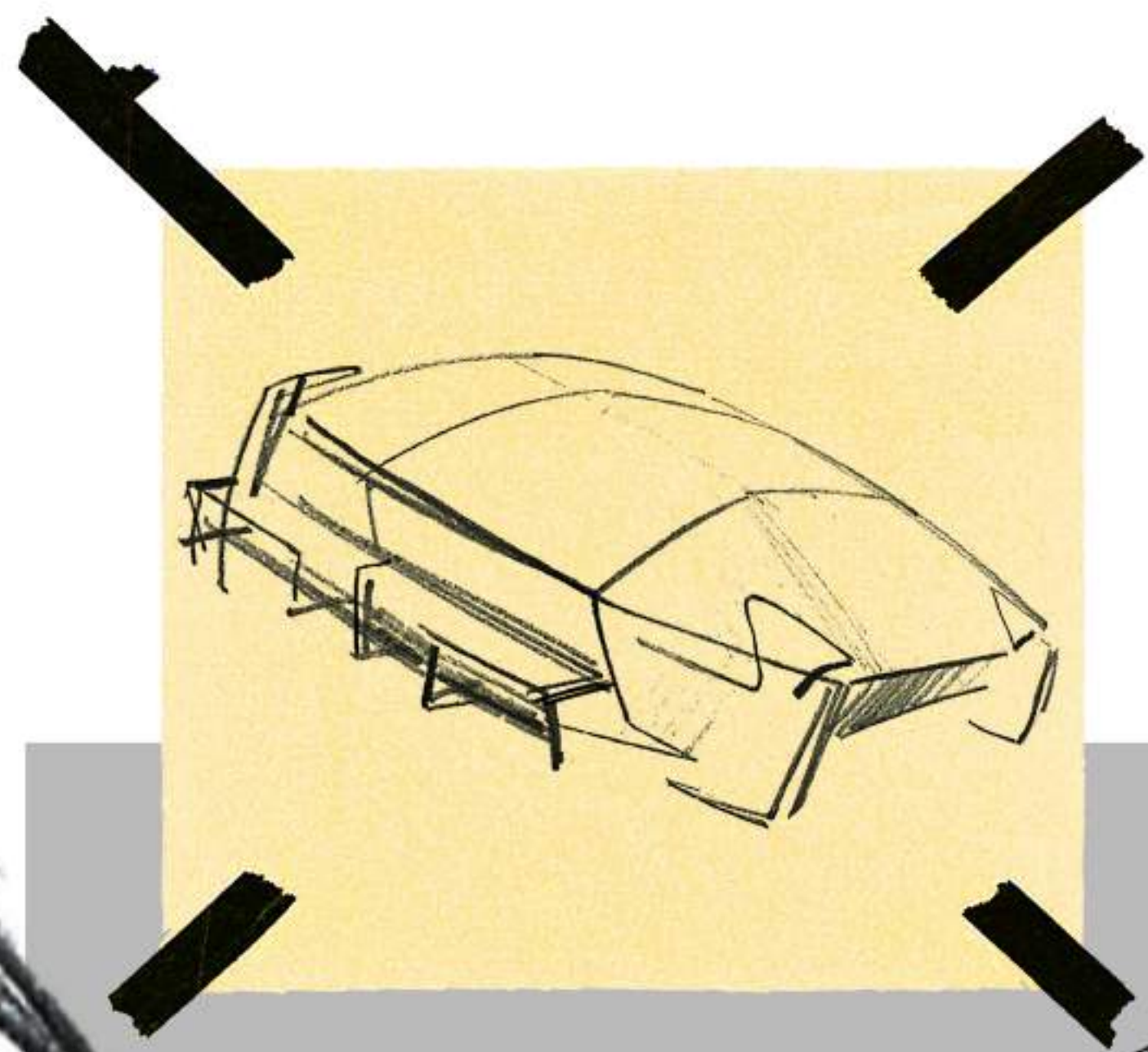
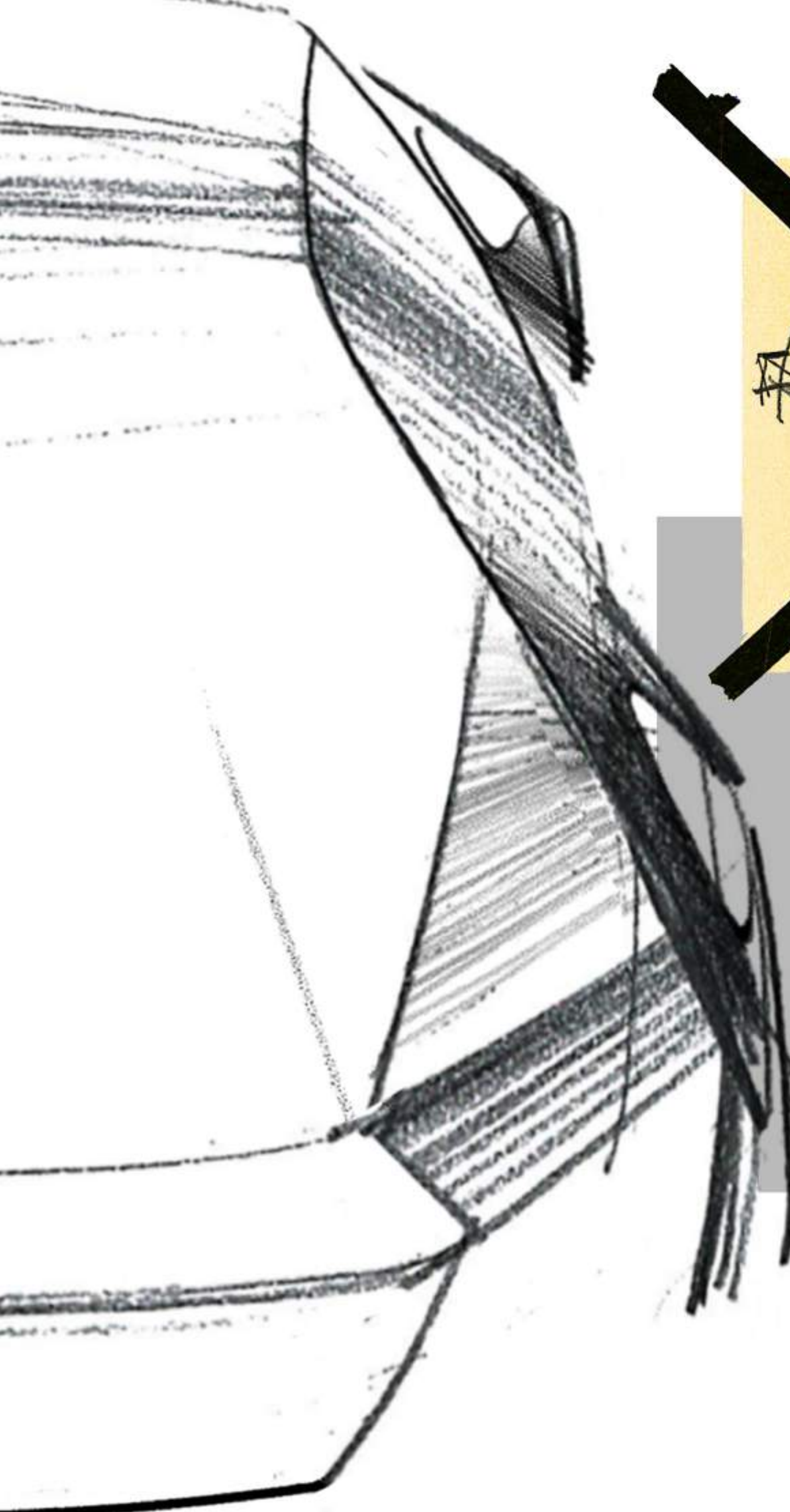

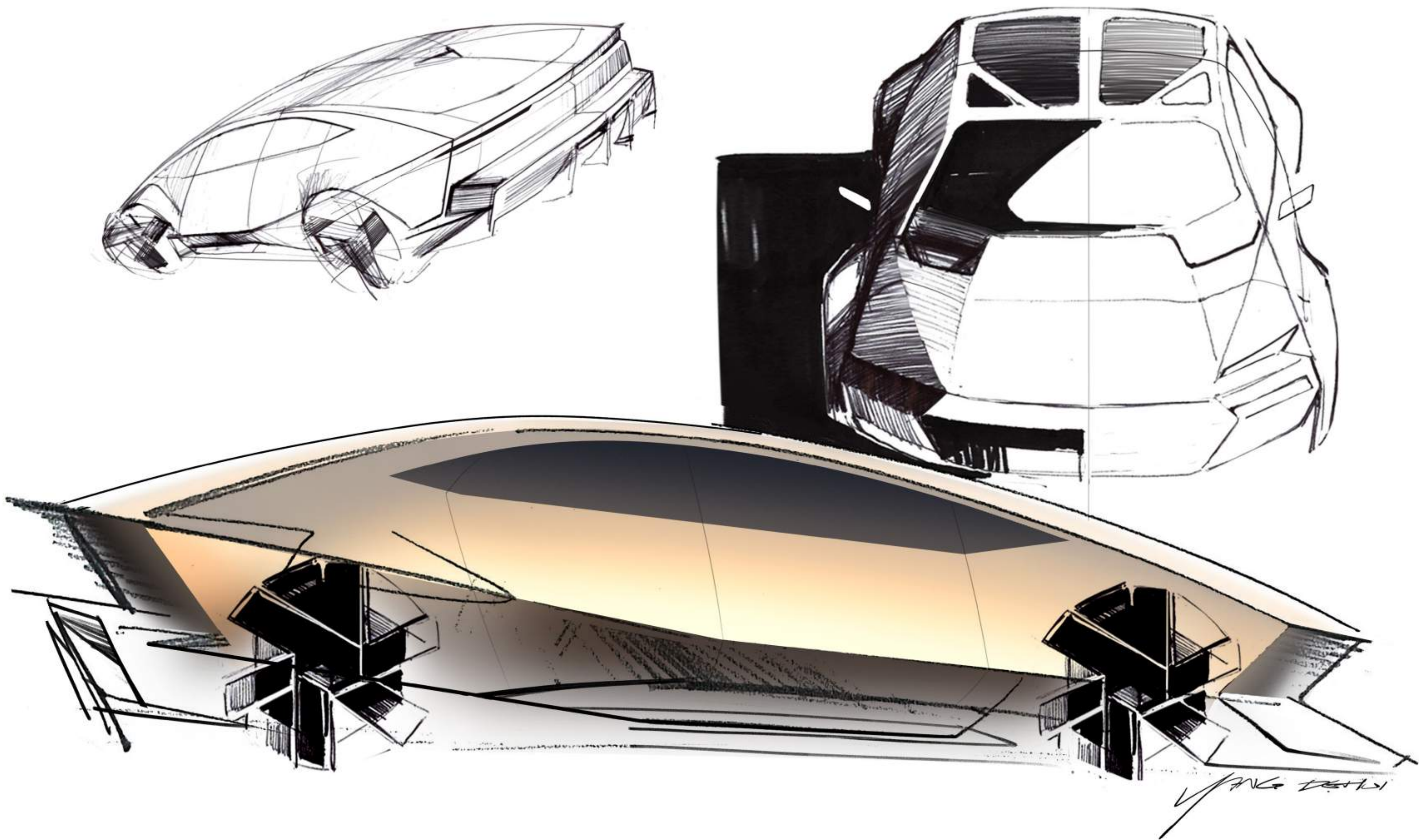

YANG 12/12/11

VENUS
C o n c e p t

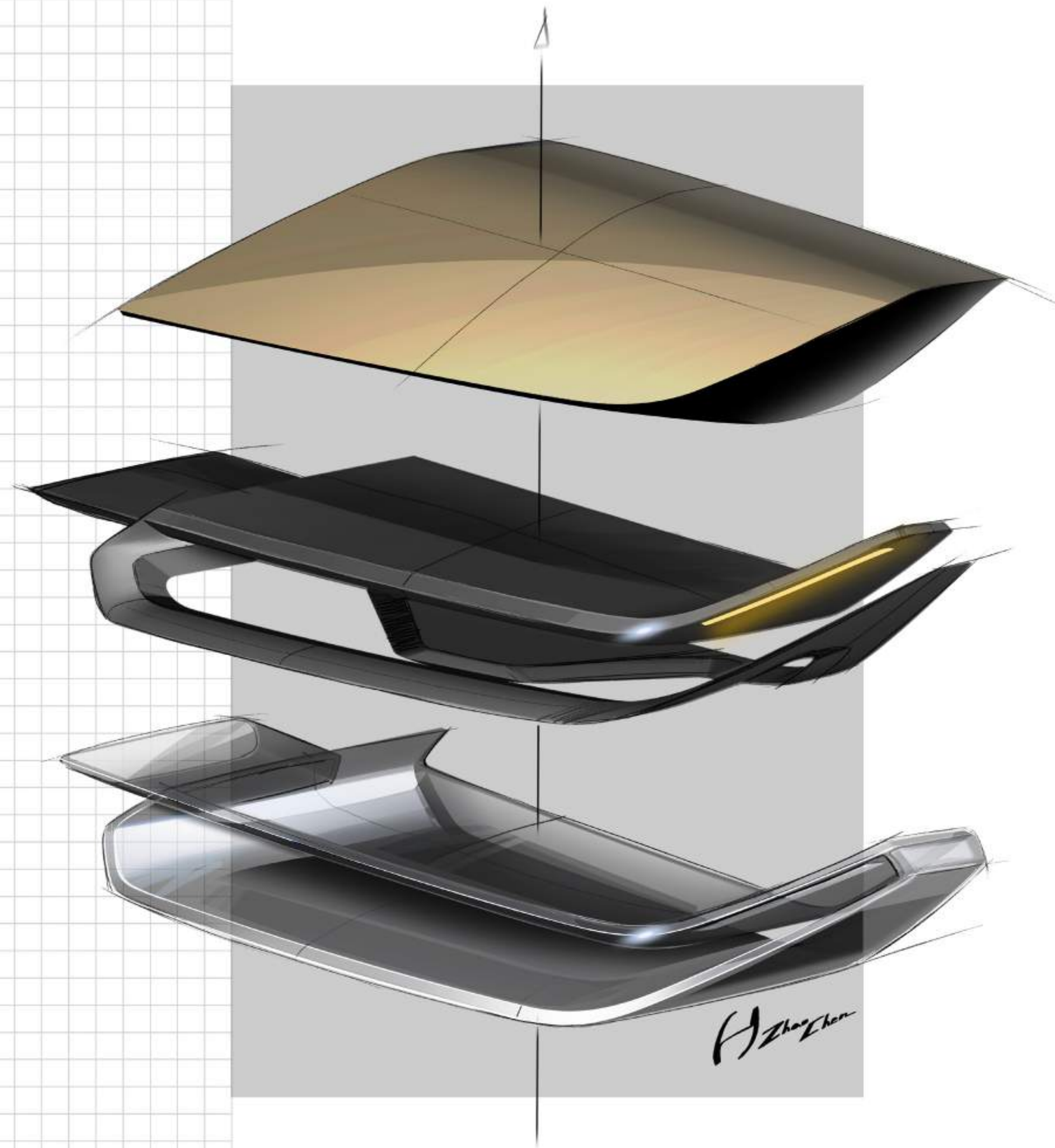

H. Zhao Chen

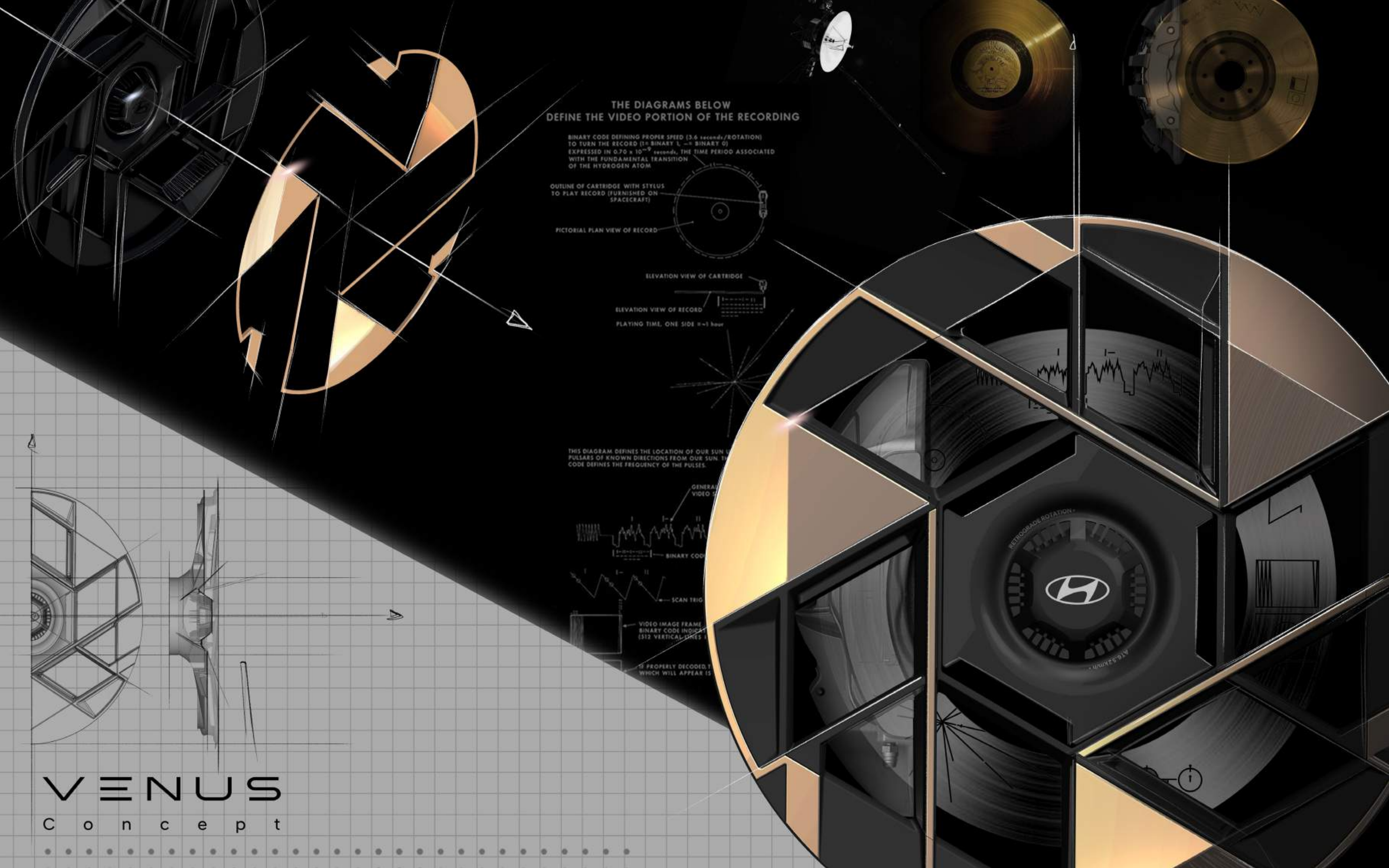

THE DIAGRAMS BELOW
DEFINE THE VIDEO PORTION OF THE RECORDING

BINARY CODE DEFINING PROPER SPEED (3.6 seconds/ROTATION)
TO TURN THE RECORD (1= BINARY 1, 0= BINARY 0)
EXPRESSED IN 0.70×10^{-9} seconds, THE TIME PERIOD ASSOCIATED
WITH THE FUNDAMENTAL TRANSITION
OF THE HYDROGEN ATOM

OUTLINE OF CARTRIDGE WITH STYLUS
TO PLAY RECORD (FURNISHED ON
SPACECRAFT)



PICTORIAL PLAN VIEW OF RECORD

ELEVATION VIEW OF CARTRIDGE

ELEVATION VIEW OF RECORD

PLAYING TIME, ONE SIDE = 1 hour

THIS DIAGRAM DEFINES THE LOCATION OF OUR SUN AND
PULSARS OF KNOWN DIRECTIONS FROM OUR SUN. THE
CODE DEFINES THE FREQUENCY OF THE PULSES.



IF PROPERLY DECODED, THE
WHICH WILL APPEAR IS

VENUS

C o n c e p t



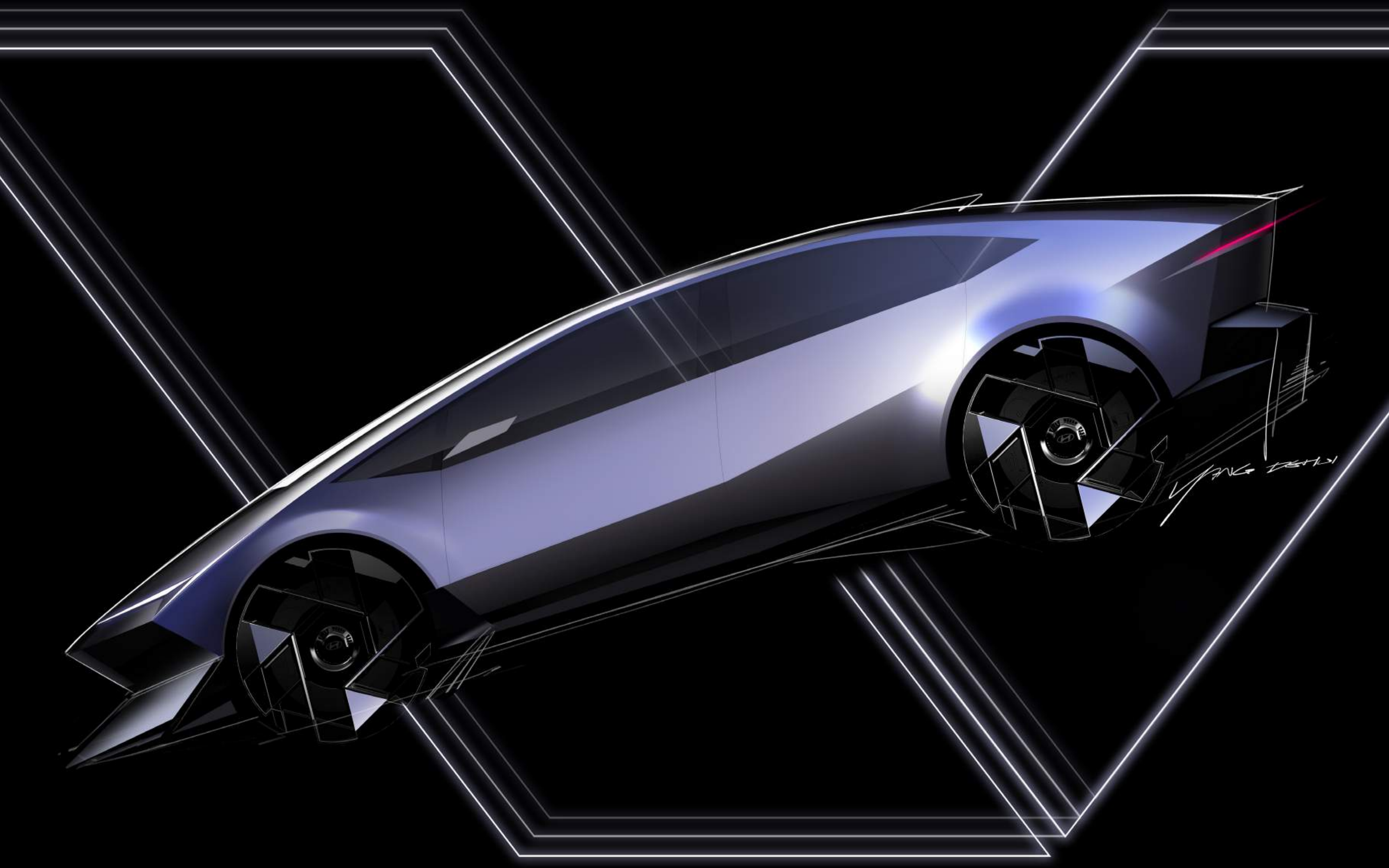

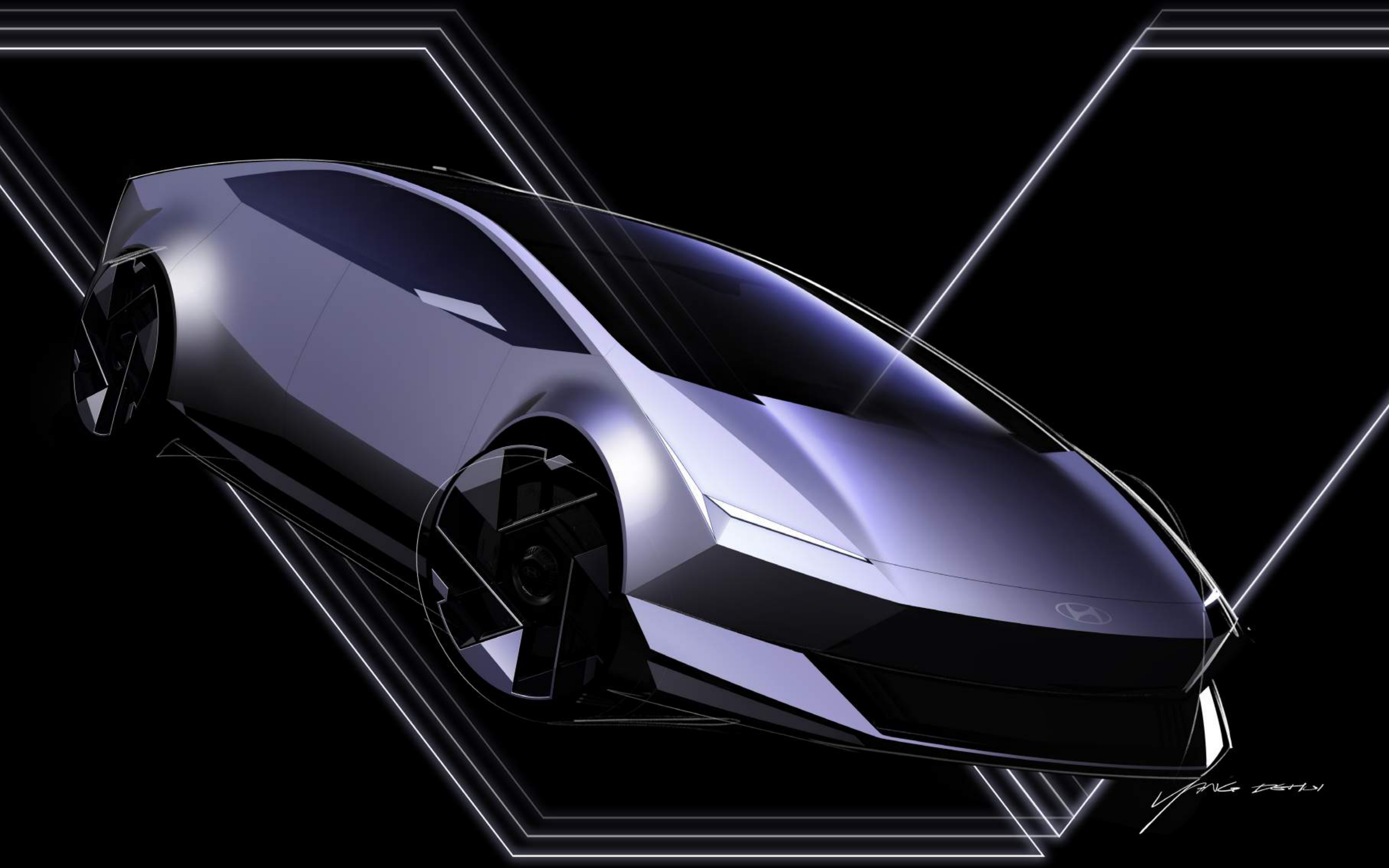

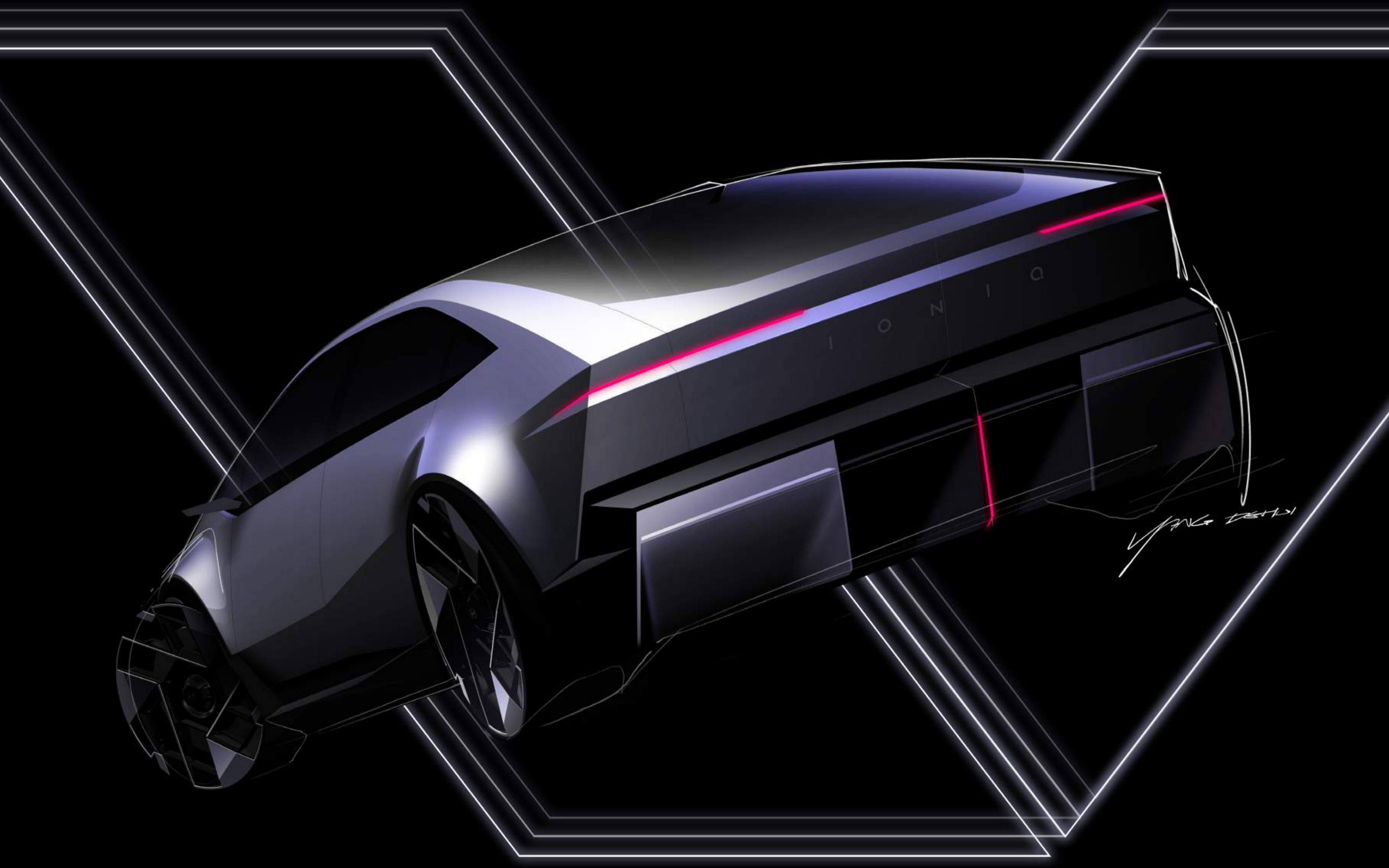

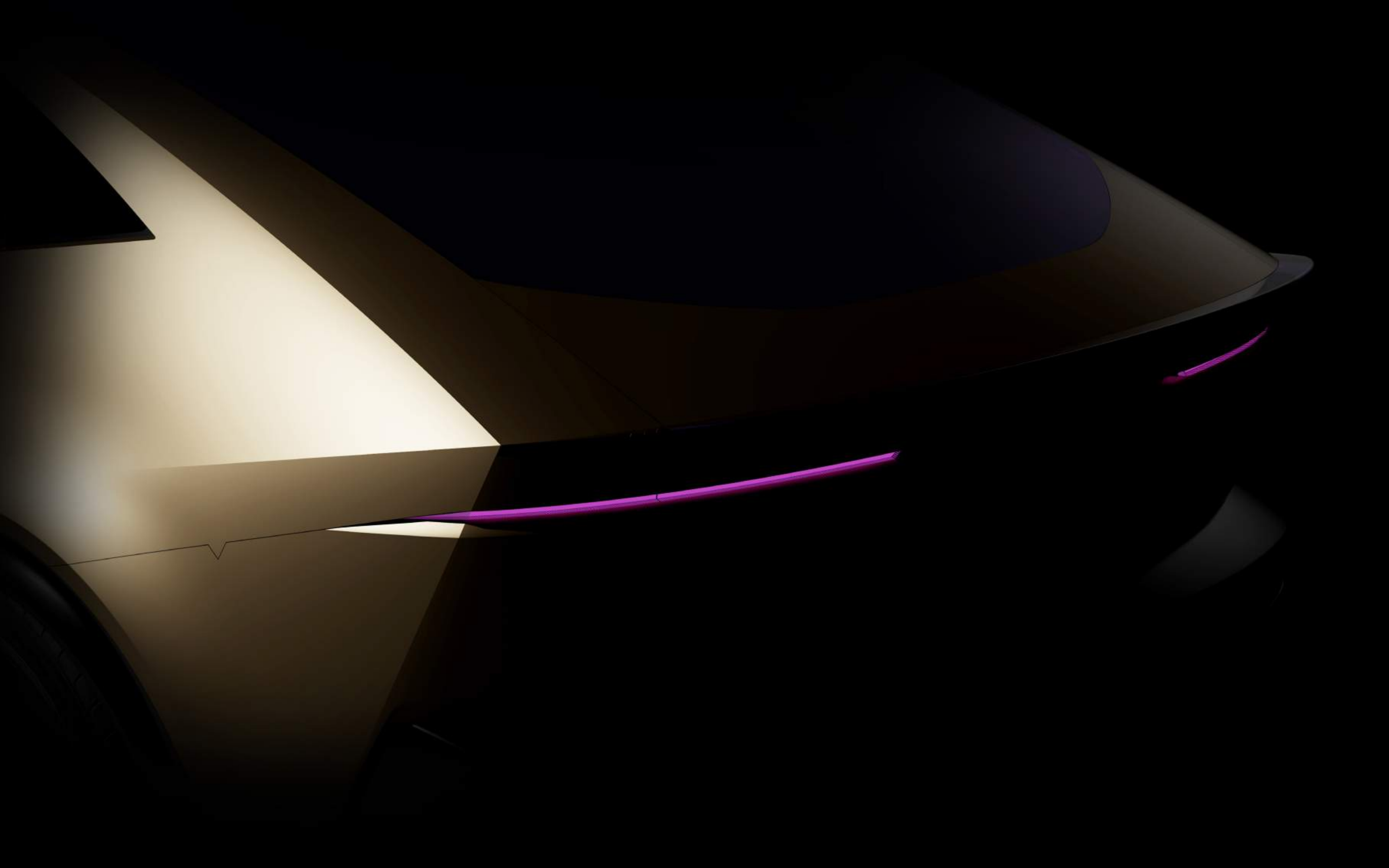

Best in WOW Moments

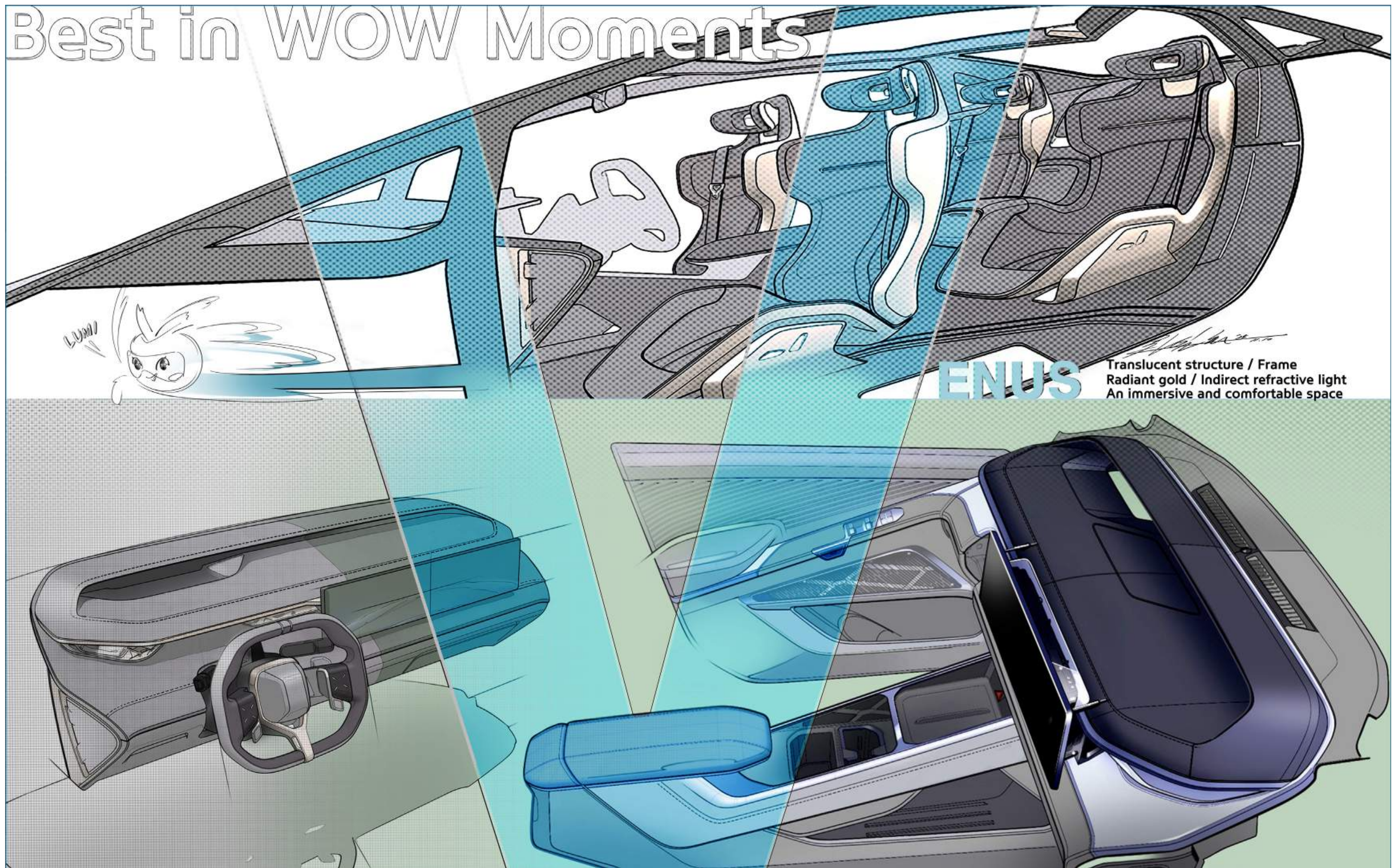

ENUS

Translucent structure / Frame
Radiant gold / Indirect refractive light
An immersive and comfortable space

DYNAMIC

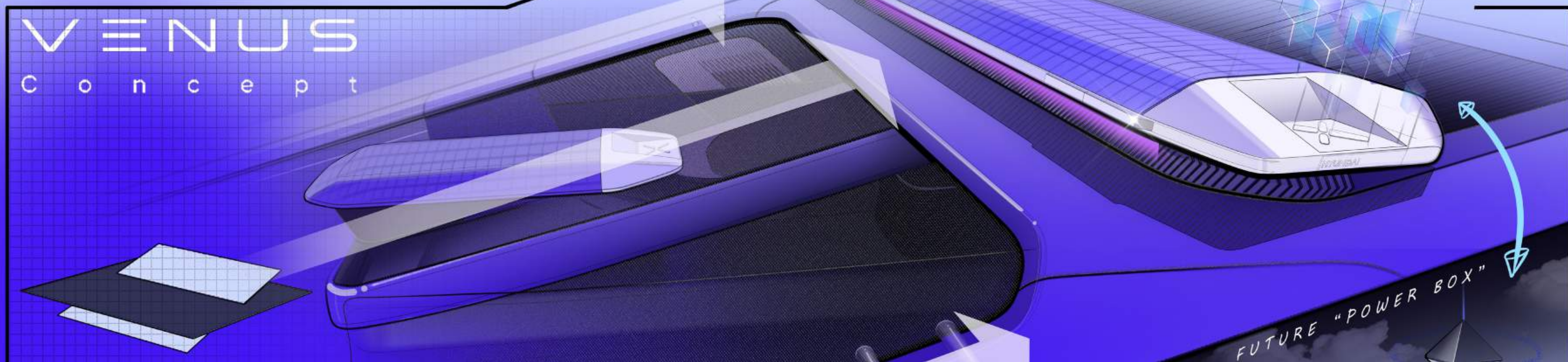
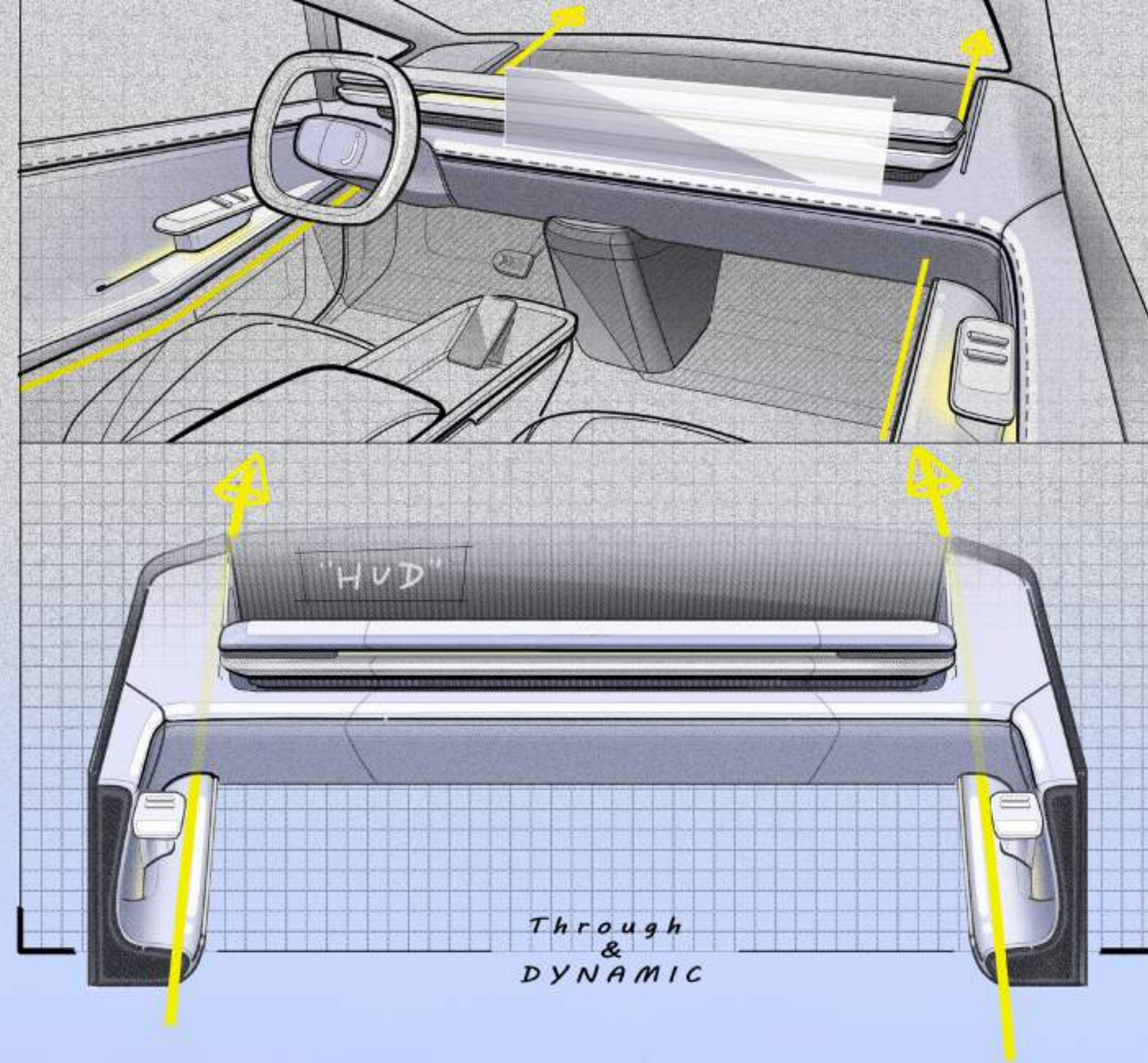
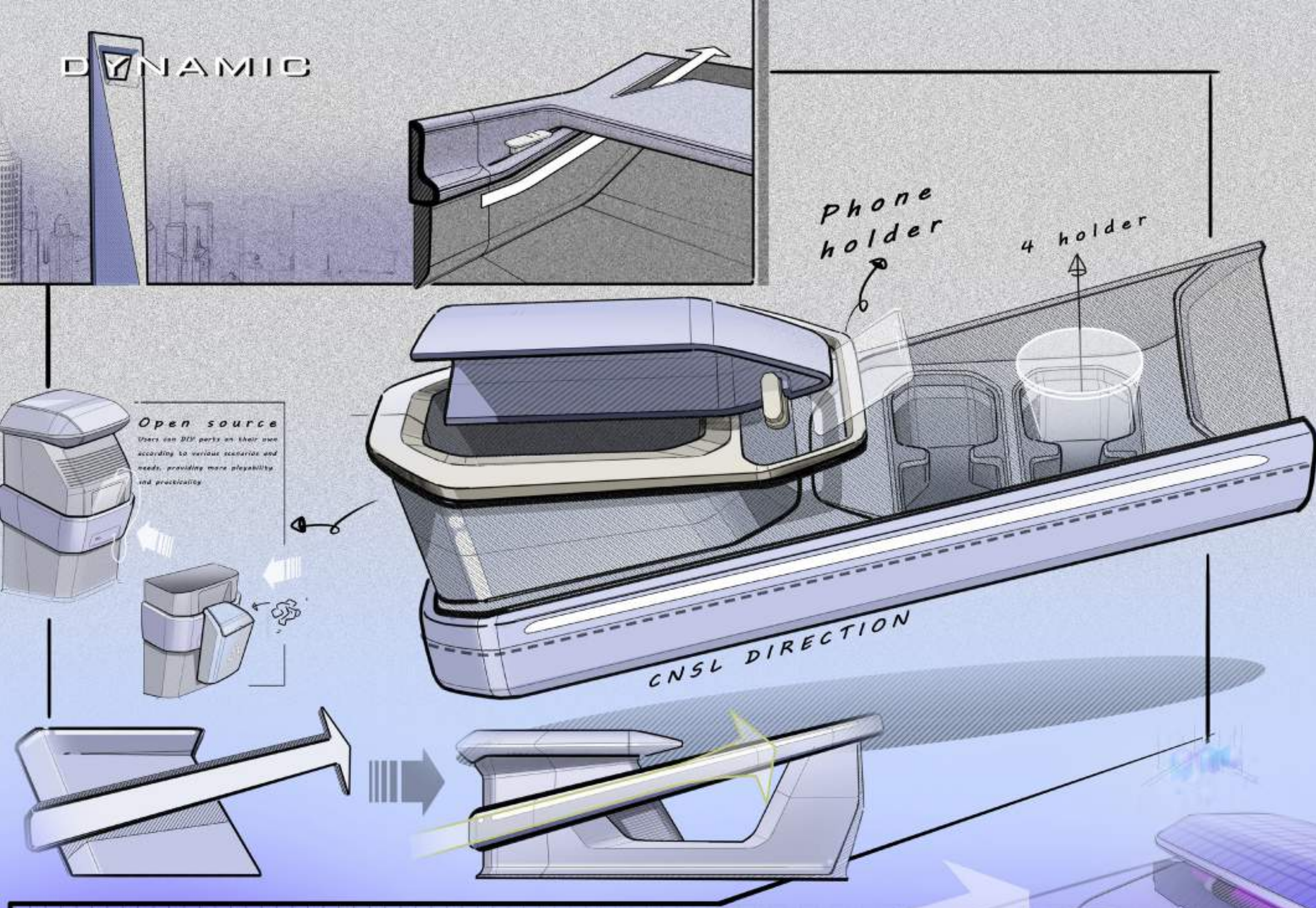

VENUS

C o n c e p t

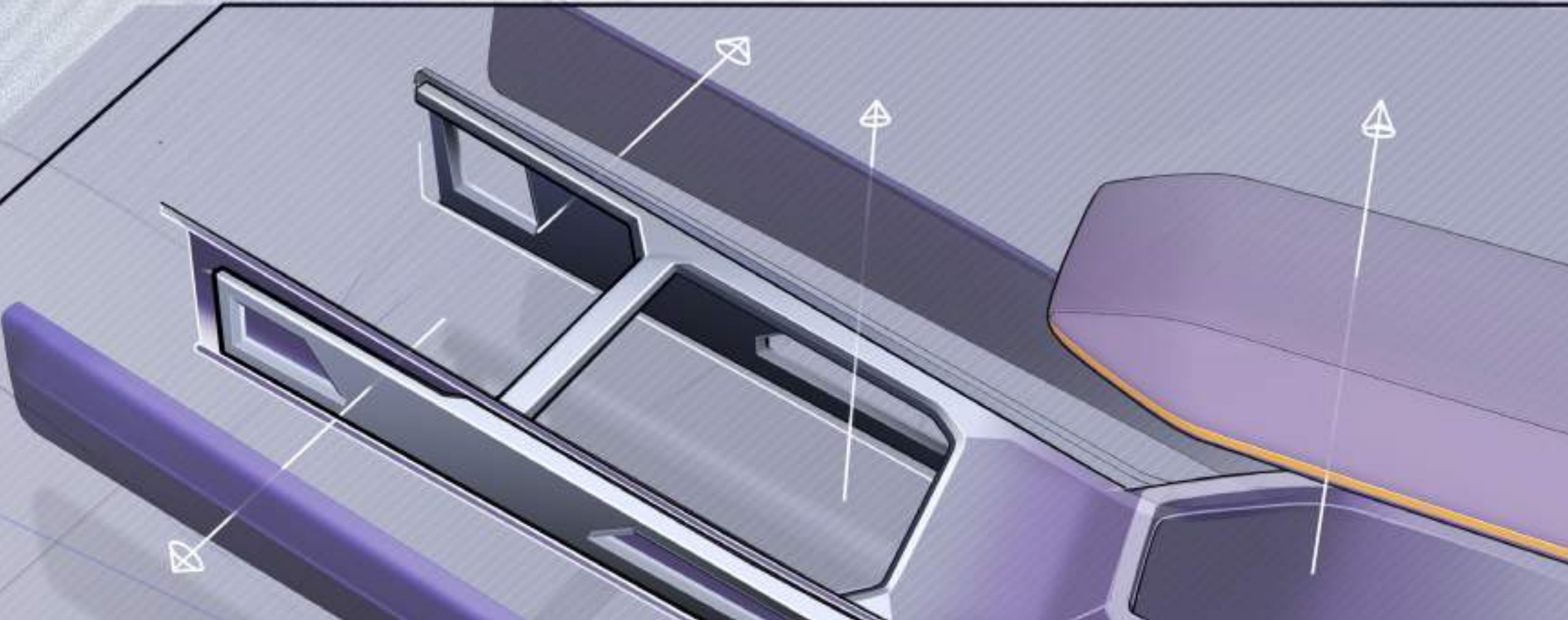
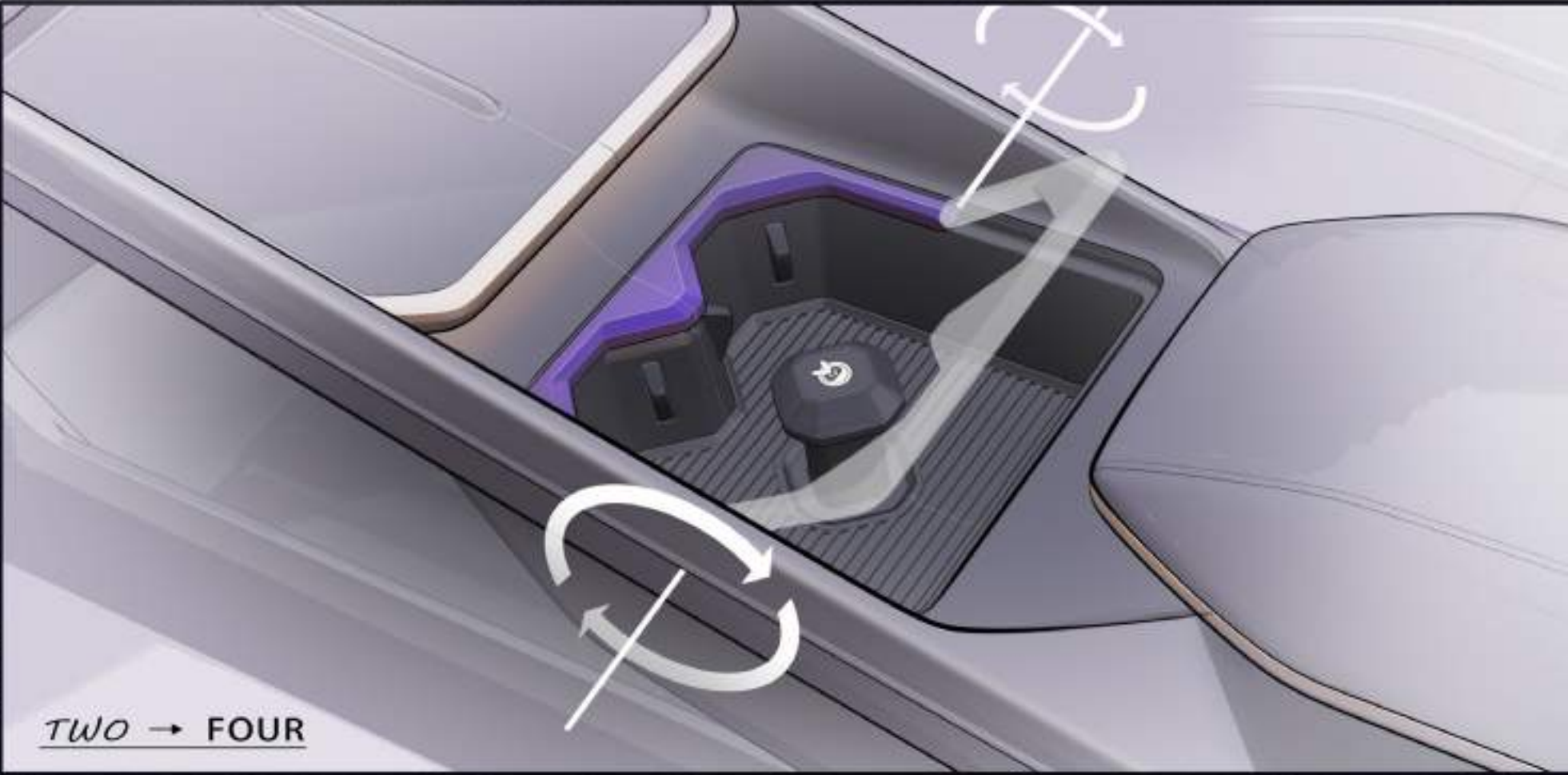
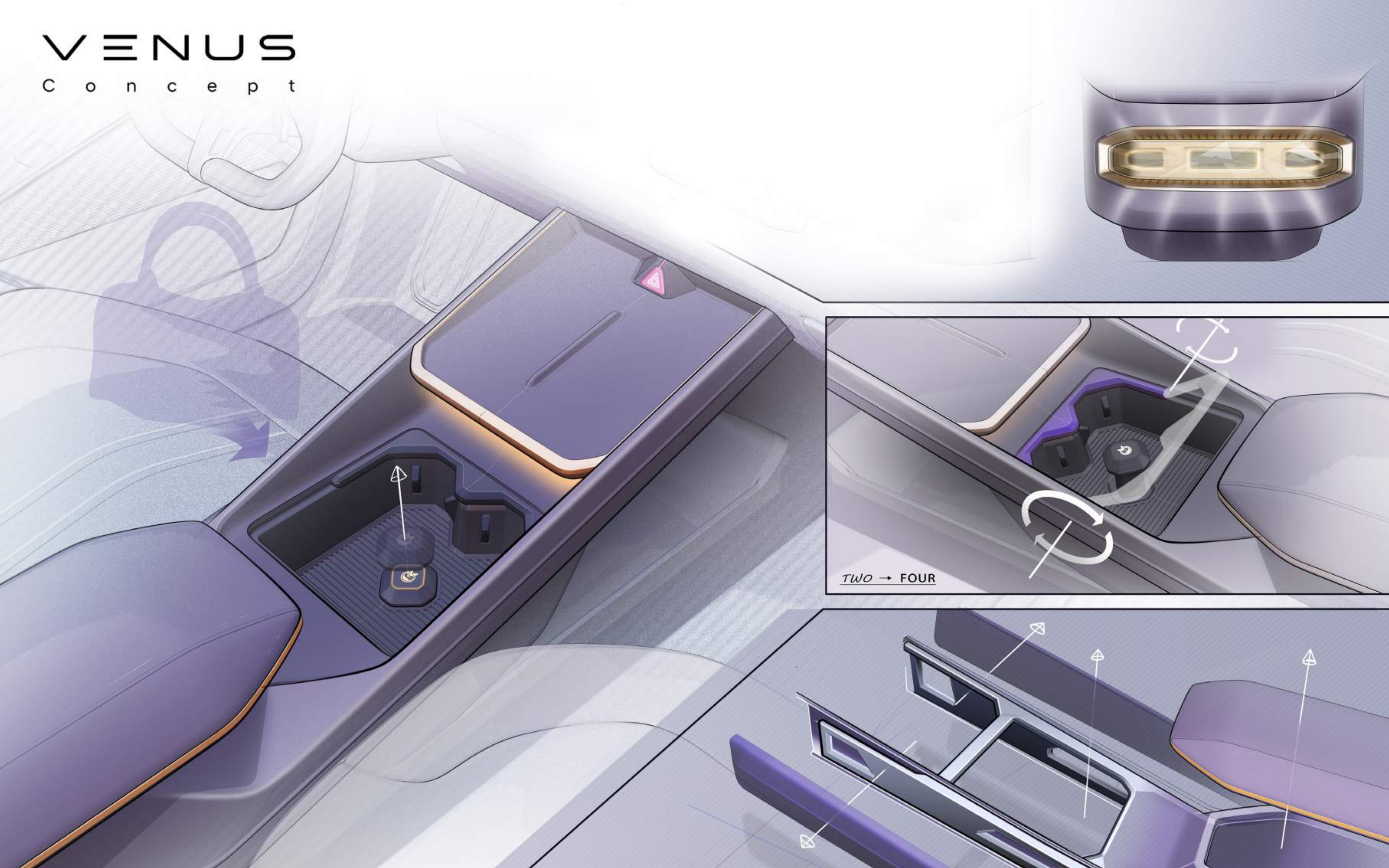

≡ A R T H
C o n c e p t



‘永恒的奇迹’

地球——宇宙中已知的唯一生命摇篮
植根于地球如奇迹般的生命力和生态平衡
这款大胆而强悍的 SUV 设计，捕捉到了地球独有的“大气”之魂

‘The Miracle of Eternal Vitality’

Earth—the only known haven of life in the cosmos.
Grounded in Earth’s miracle-like vitality and biological
balance, this bold and powerful SUV design captures the
essence of air—unique to our planet.



极光之盾

极光，是可持续与美感共生的象征
以此为灵感，依托紫绿炫彩演绎沉静隽永之力，将守护升华成艺术之美

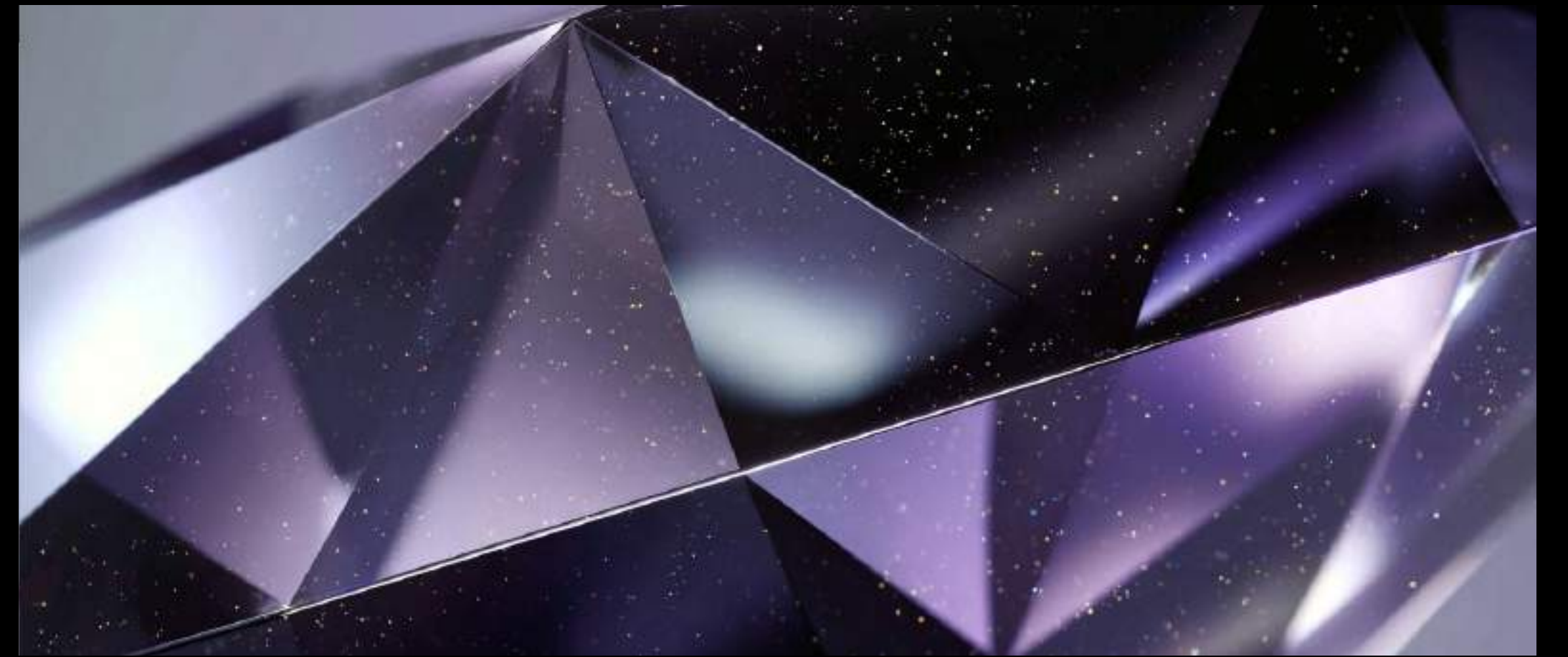

Aurora Shield

The aurora stands as an icon of sustainability—beauty in harmony. Inspired by Earth's aurora, our purple-green iridescent finish turns protection into art, reflecting a calm, constant strength.

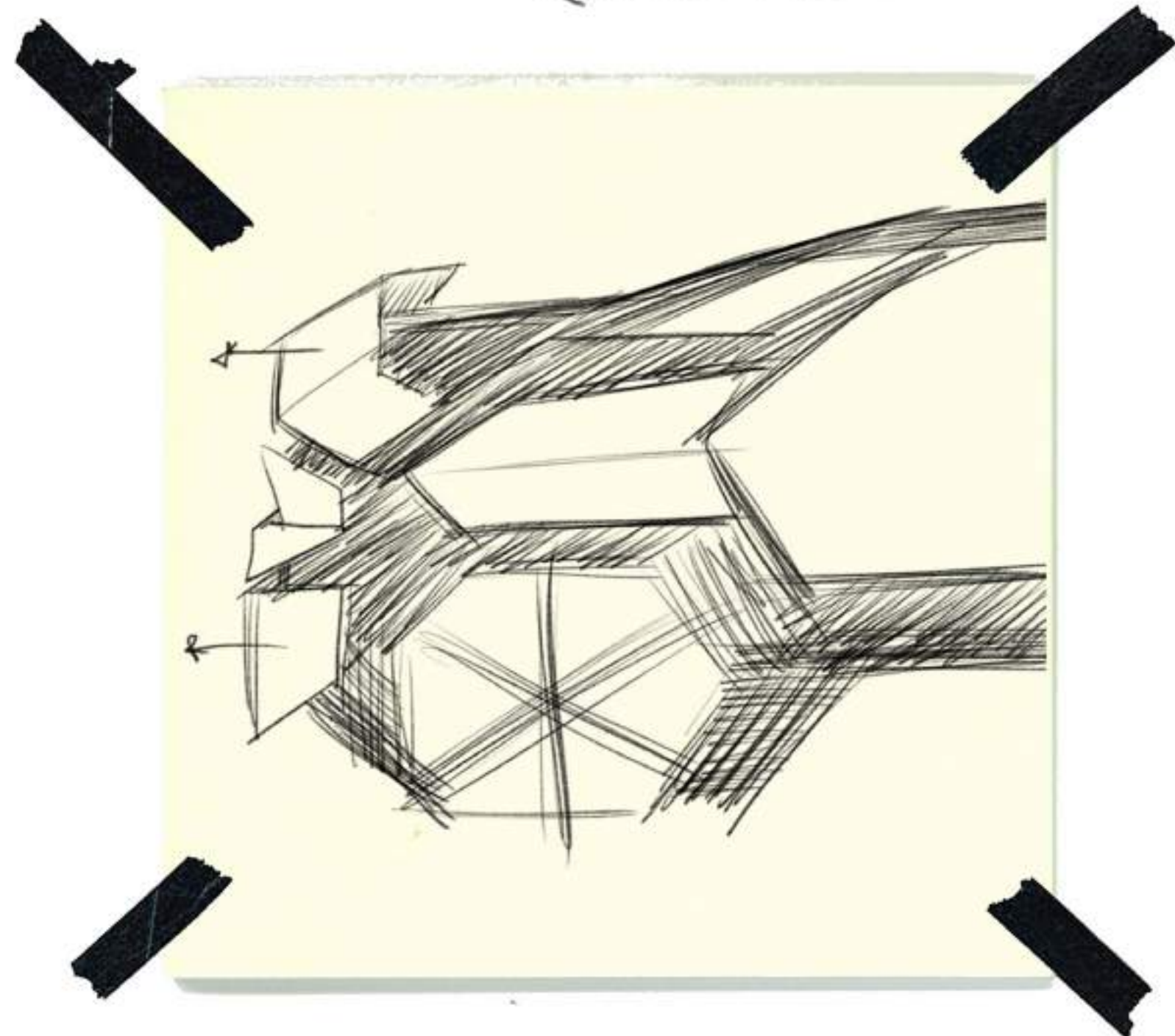
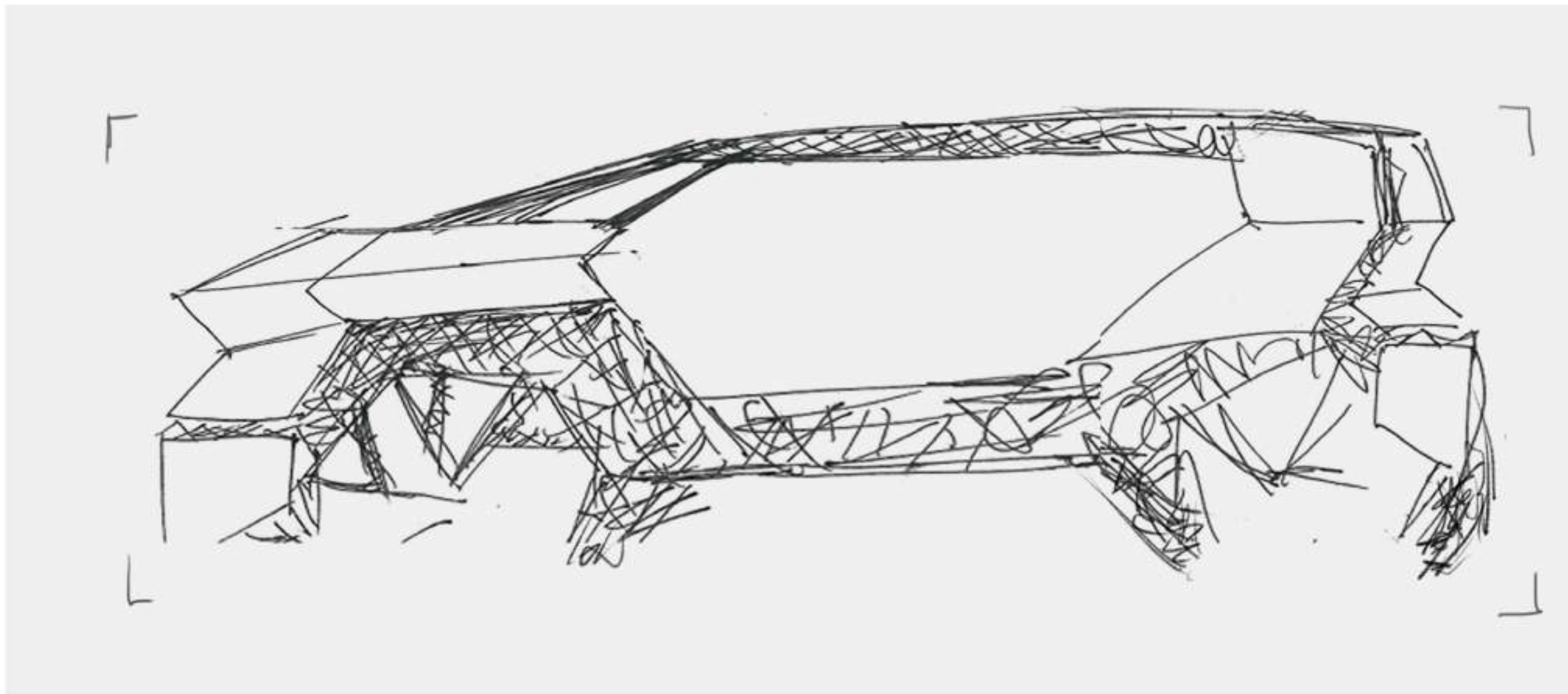
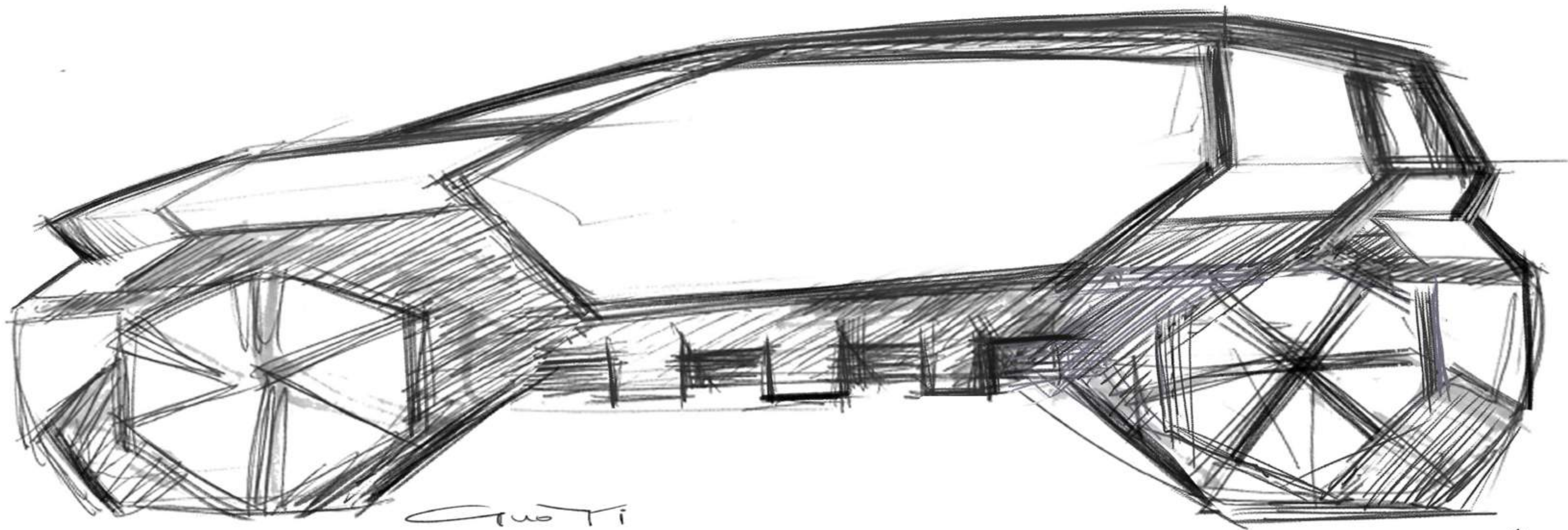

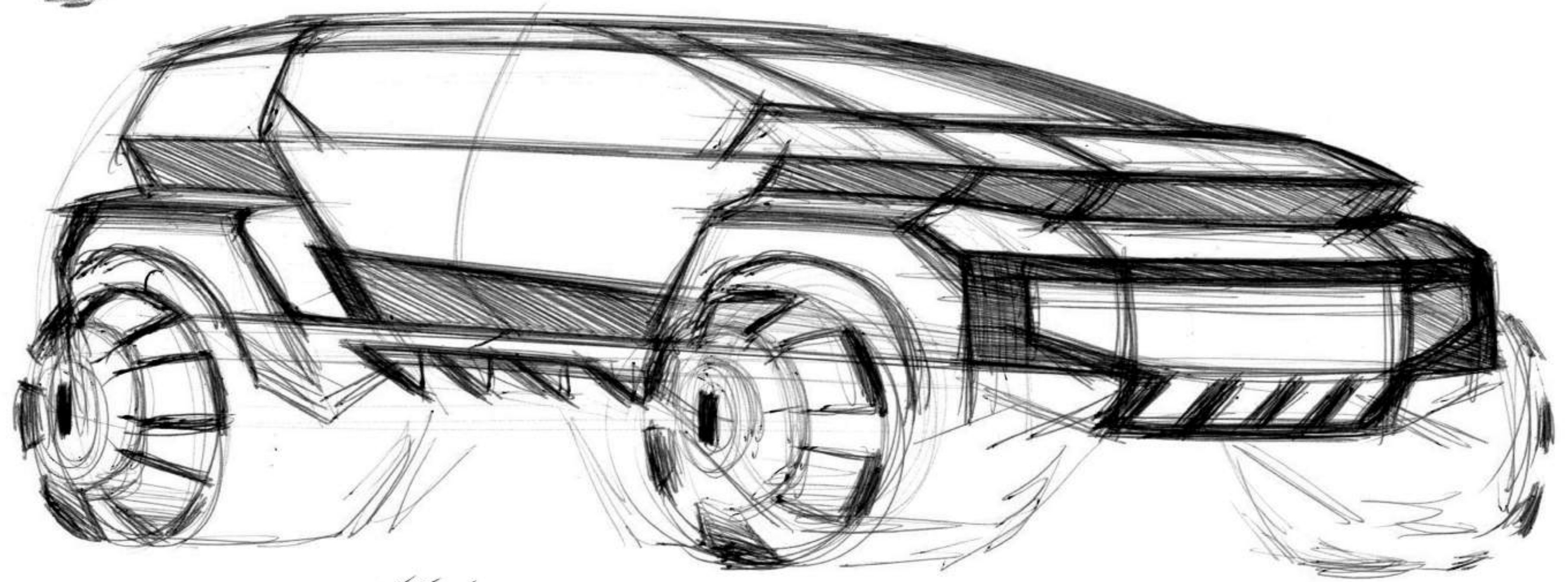
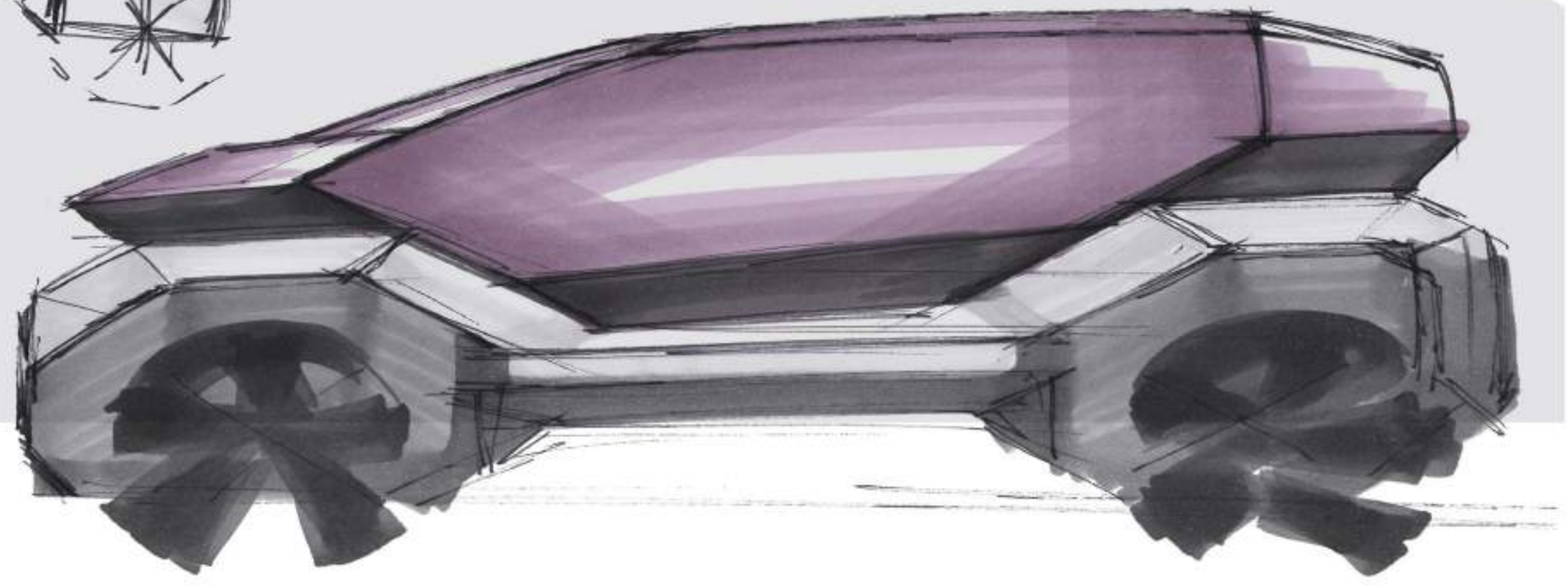
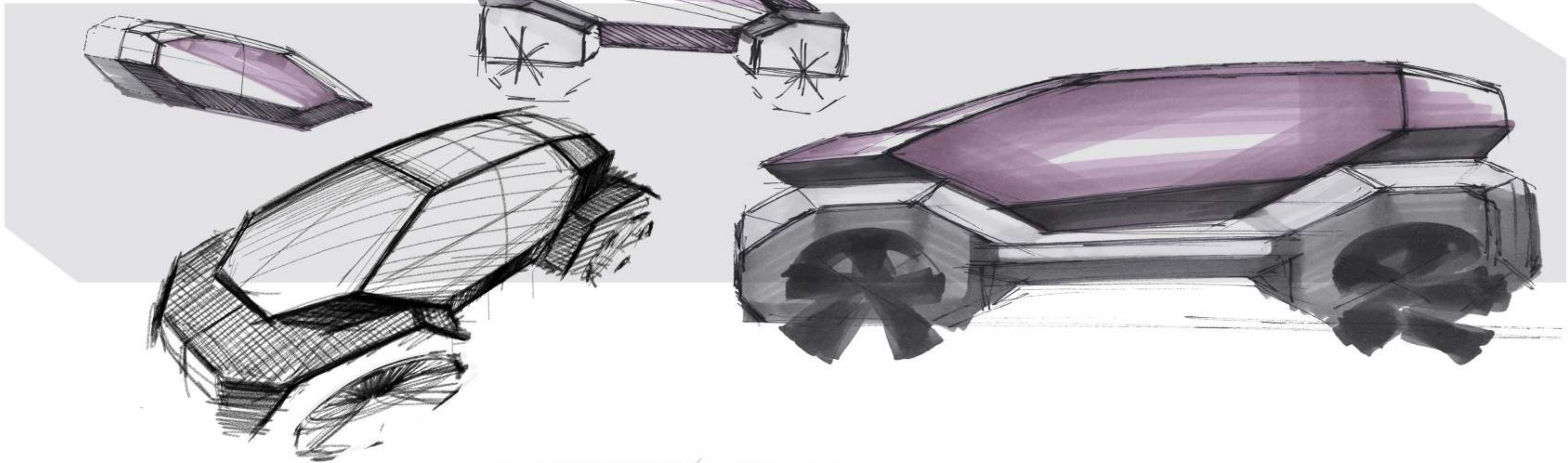

EARTH
concept

W. Xuecheng

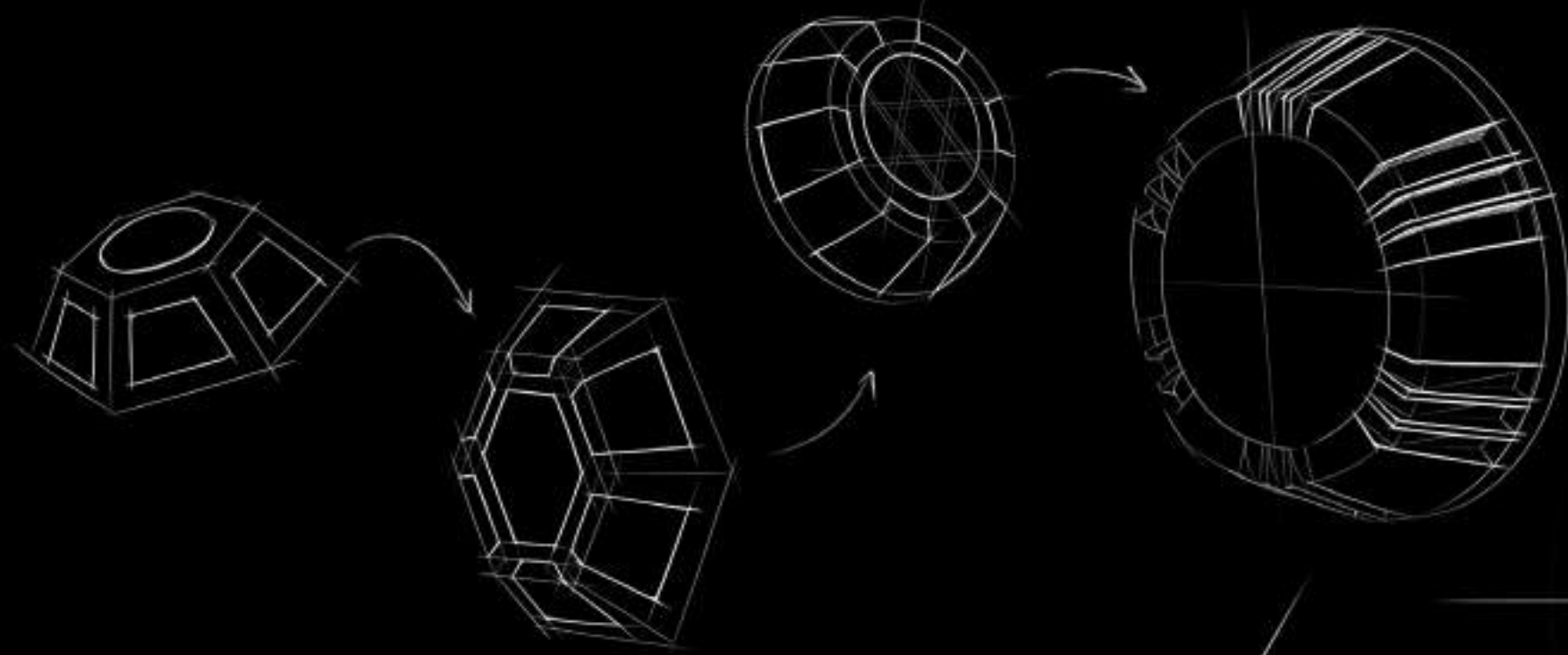

Earth's rotation speed

at 1670 km/h

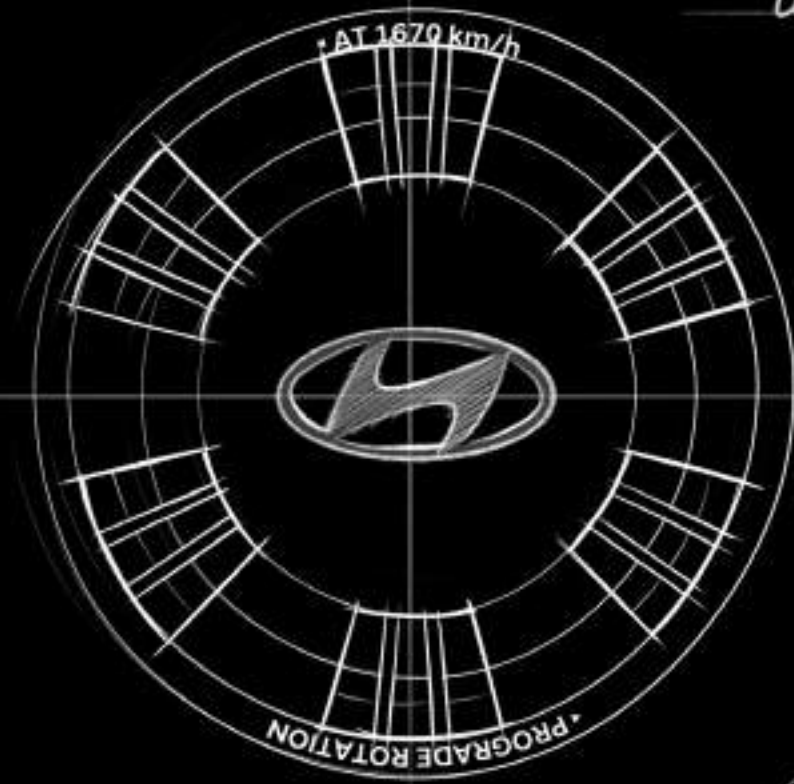

Space station

Atmosphere

Ground

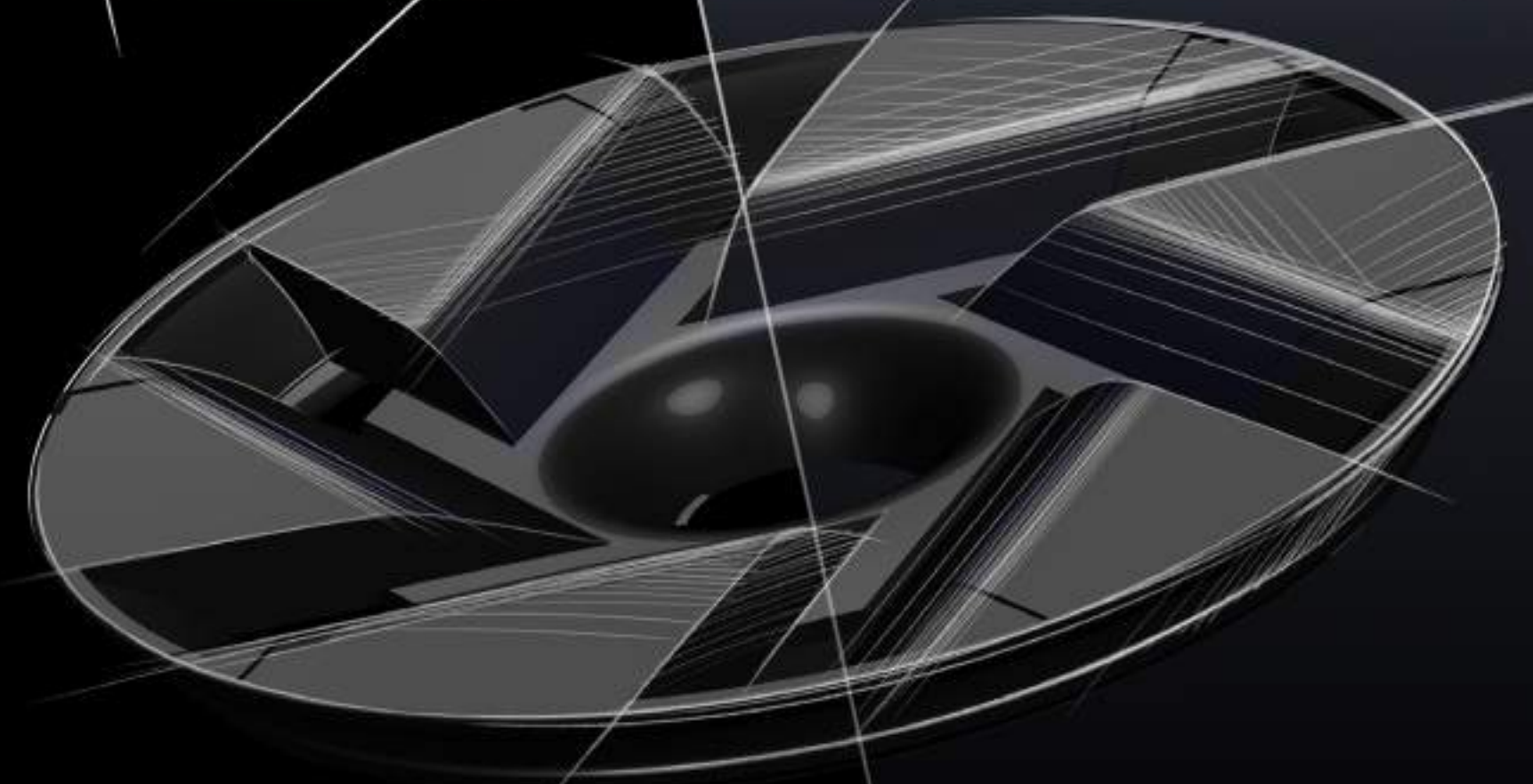
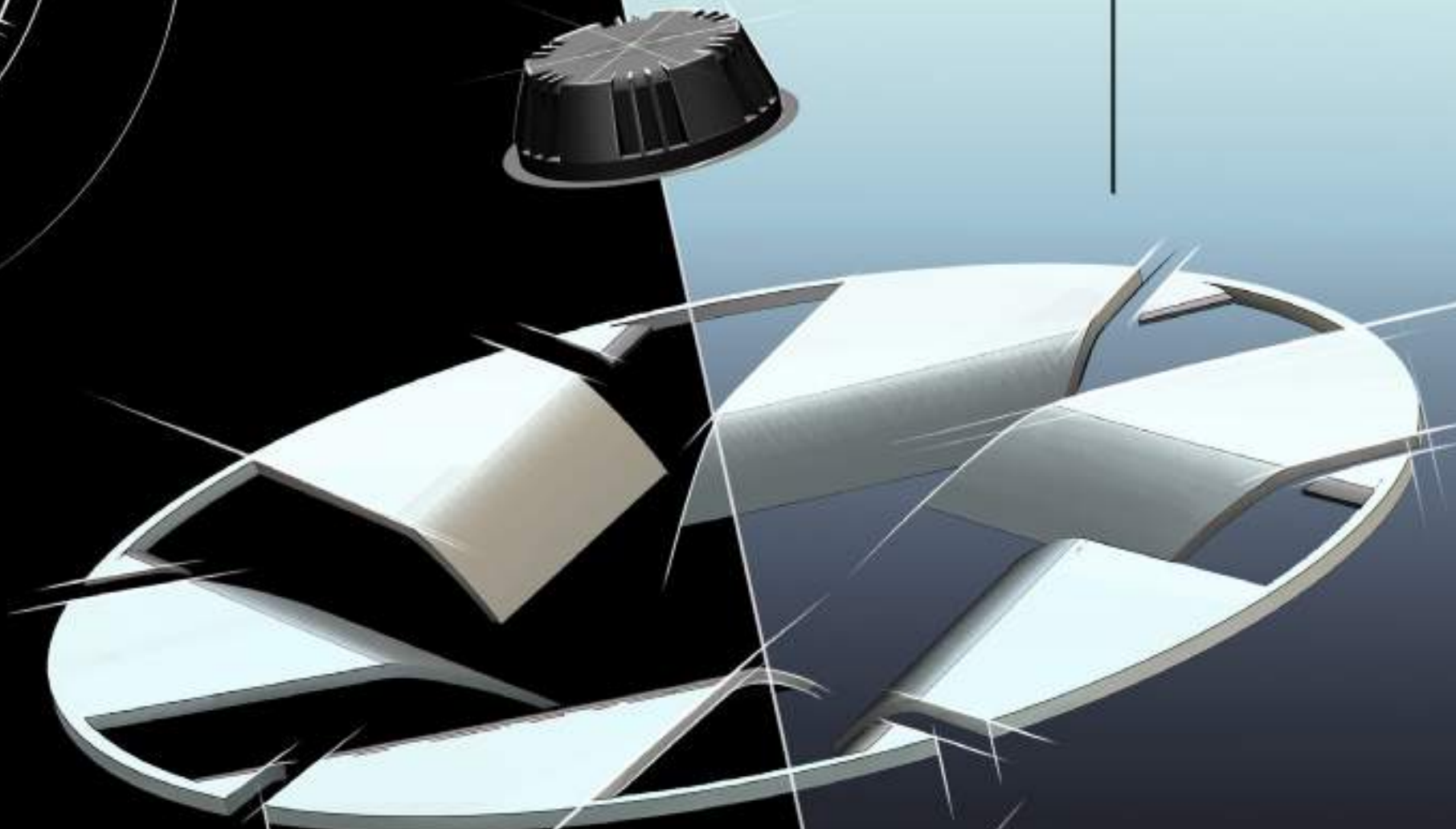

≡ EARTH
C o n c e p t

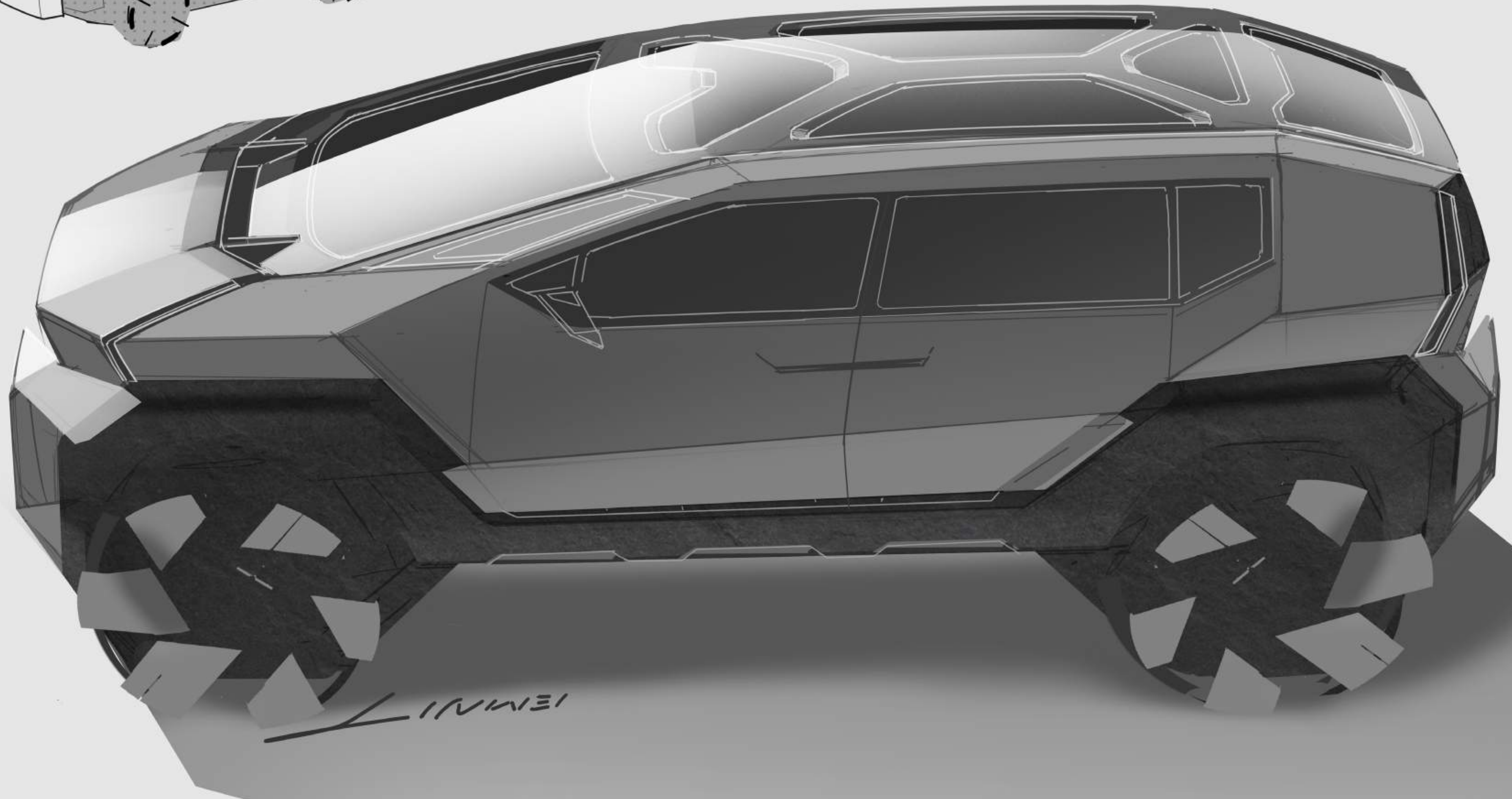
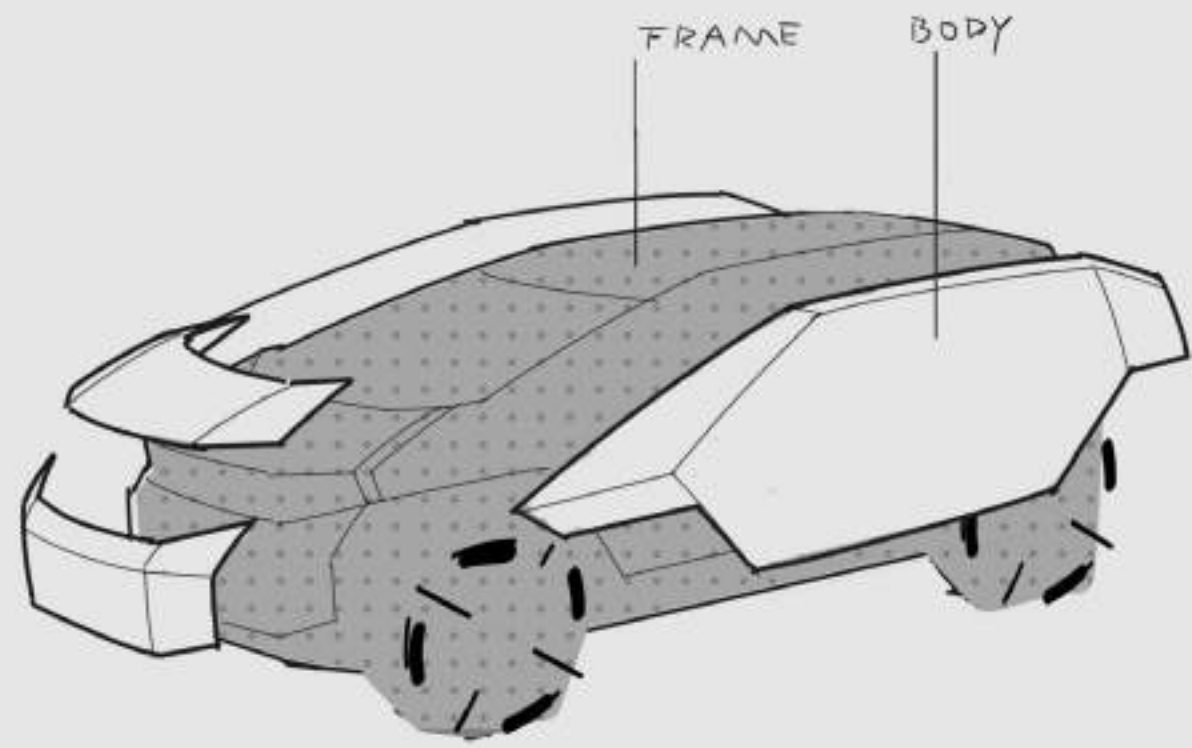

EARTH
C o n c e p t

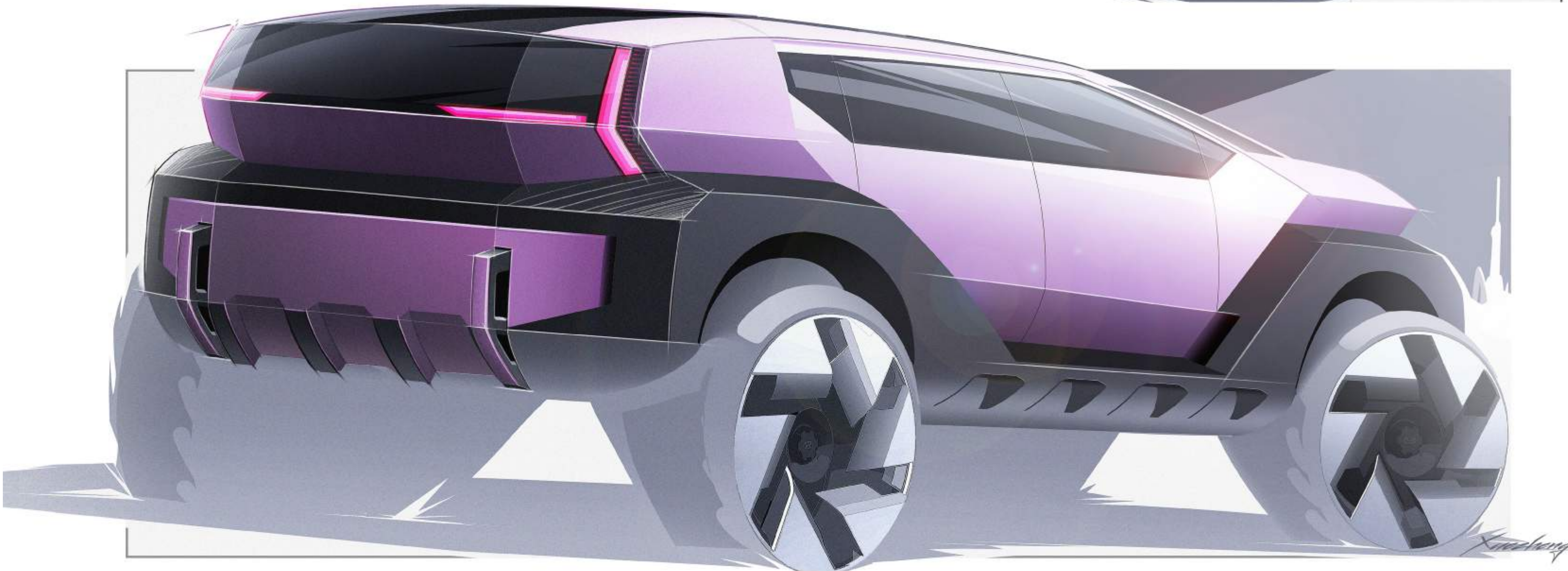
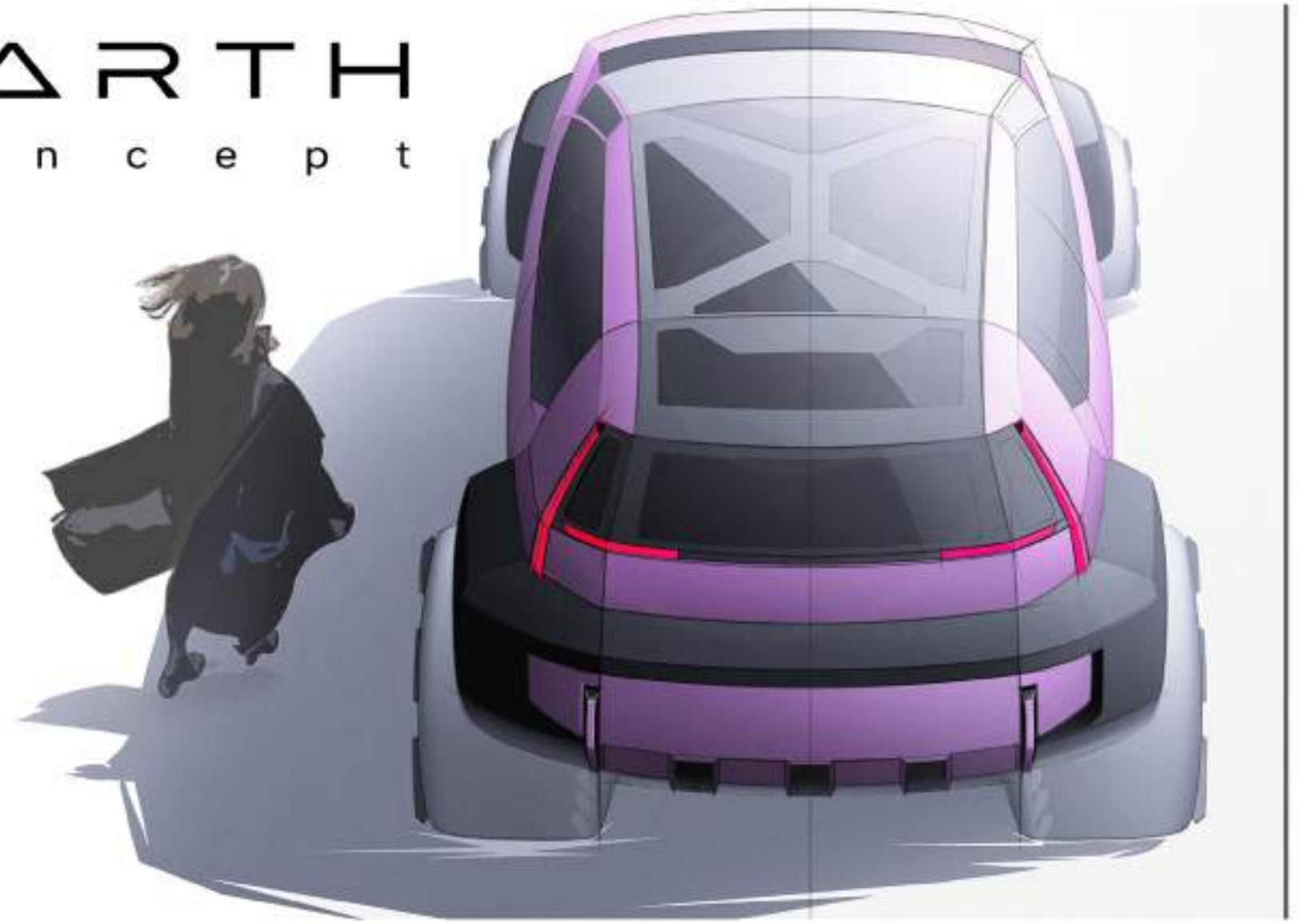

ΞARTH
C o n c e p t



x
9+6

EARTH
C o n c e p t

X
9+6

EARTH



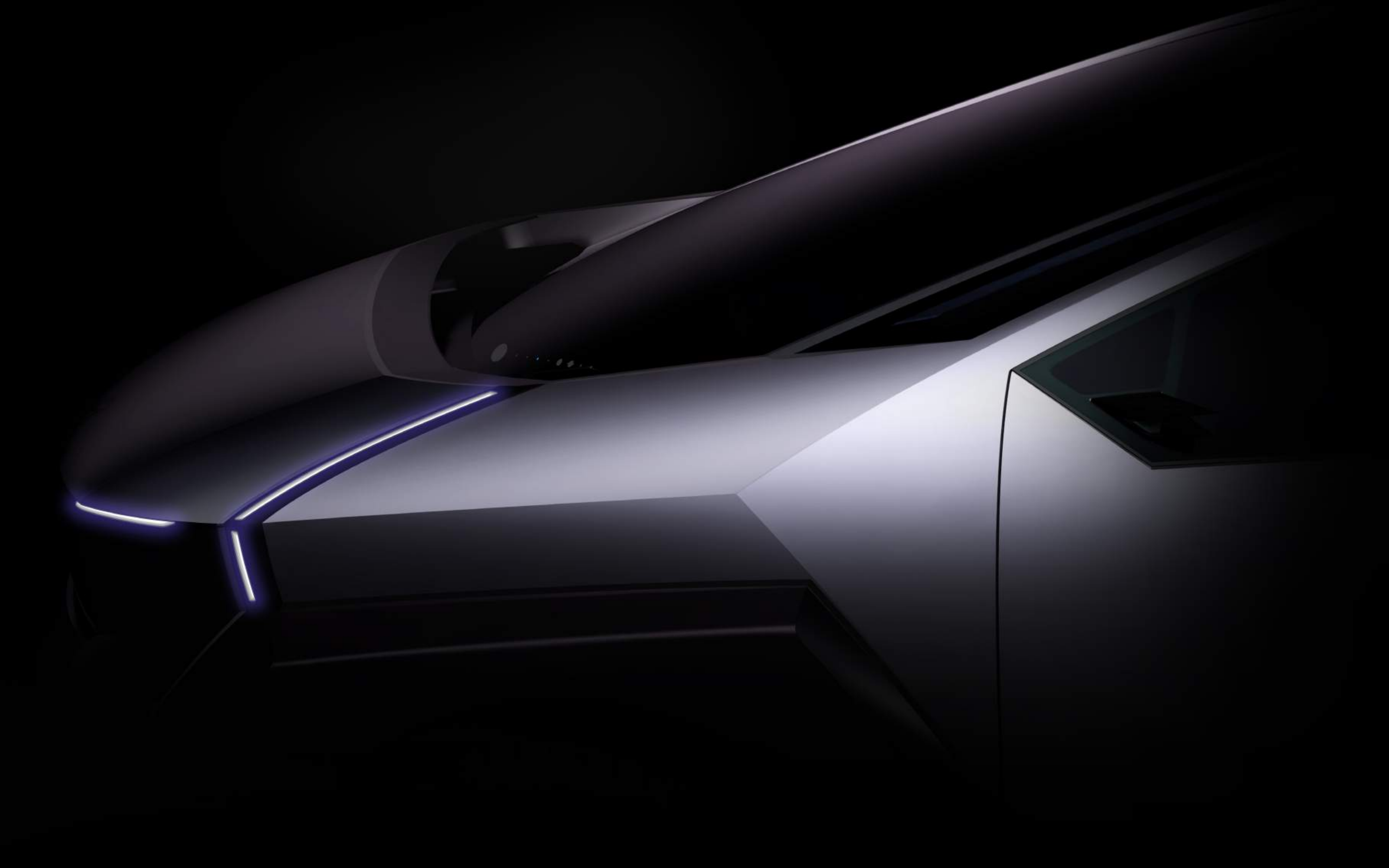

EARTH
Concept

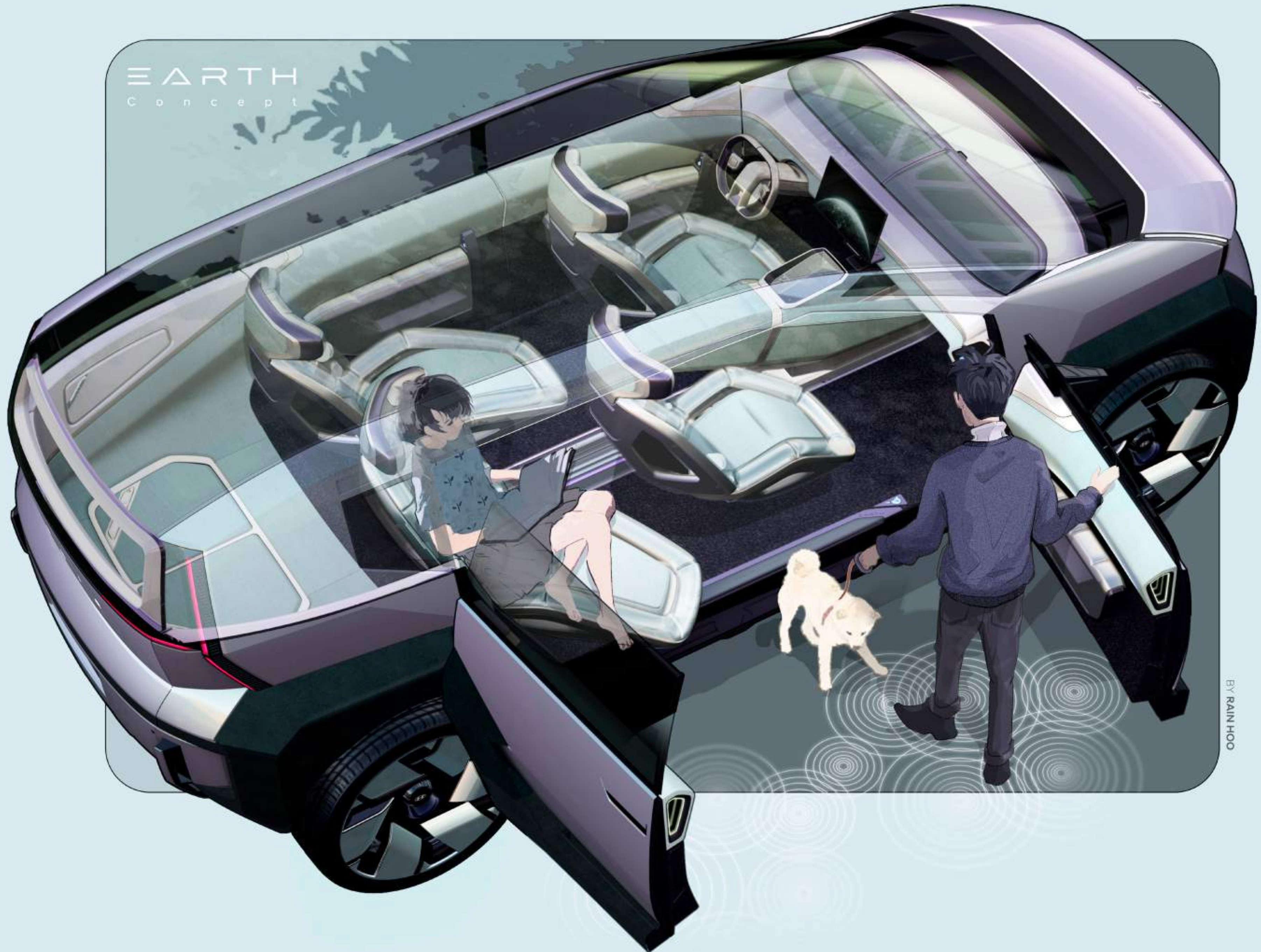

BY RAIN HOO

EARTH

C o n c e p t





EARTH

IONIQ Brand Film

Intro

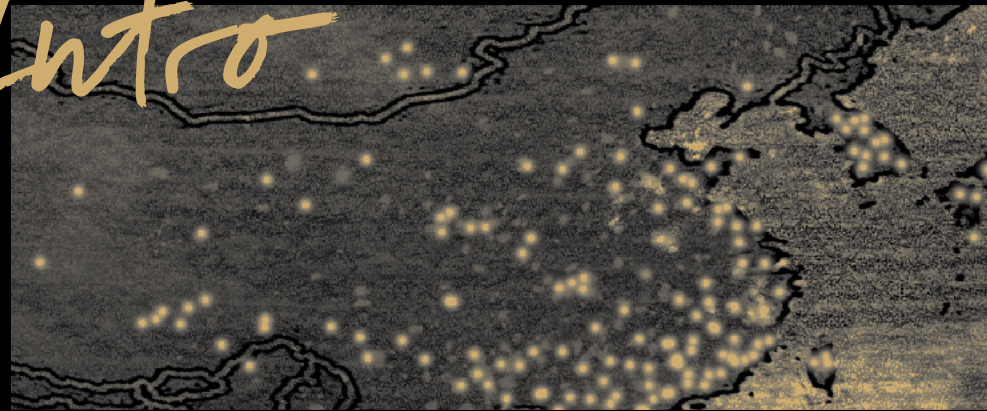

Scene 01
After the star-filled universe unfolds, China, seen from a satellite, appears like a starry sky.



Scene 14
From the POV of 'The Origin', China's diverse landscape is shown.



Scene 26
'The Origin' slowly descends into the city.

19:20

With people



Scene 31
On a hip street, people stare at 'The Origin'.

Zooming out

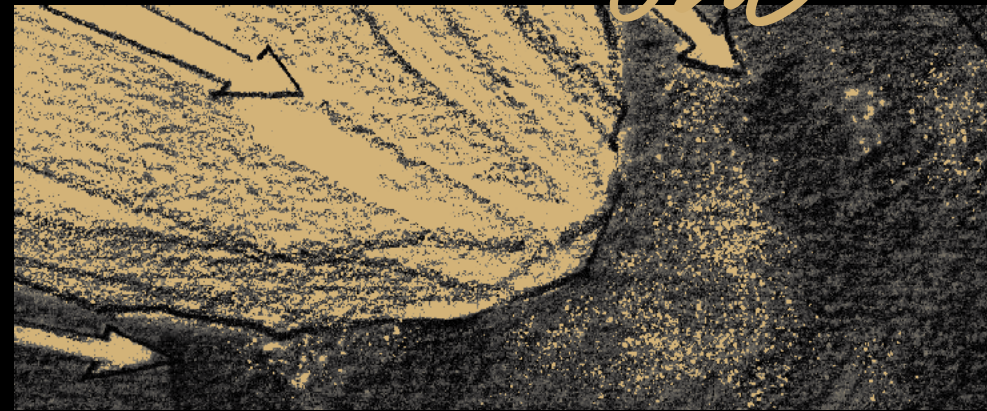

Scene 03
'The Origin' descends, withstanding intense external forces.



Scene 17
A woman walks along Wukang Road-Anfu Road and looks up at the sky.

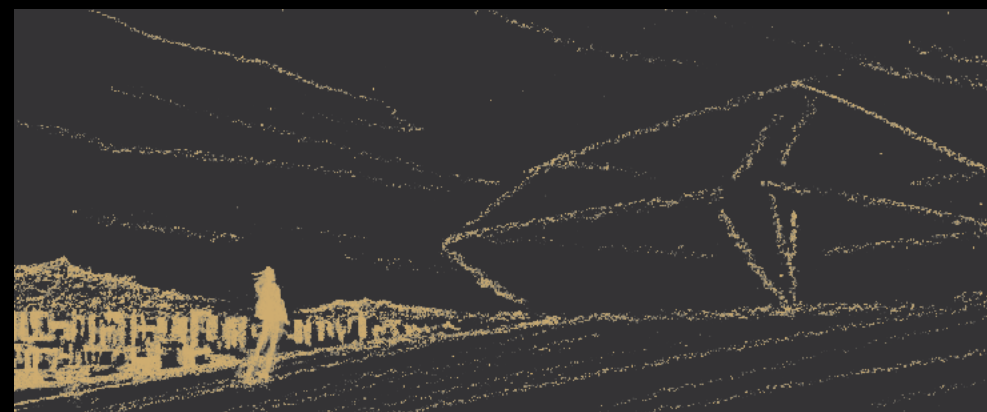

Scene 30
'The Origin' slowly descends, tilting horizontally, and faces the man.



Scene 34
'The Origin' rapidly approaches and meets the main characters.

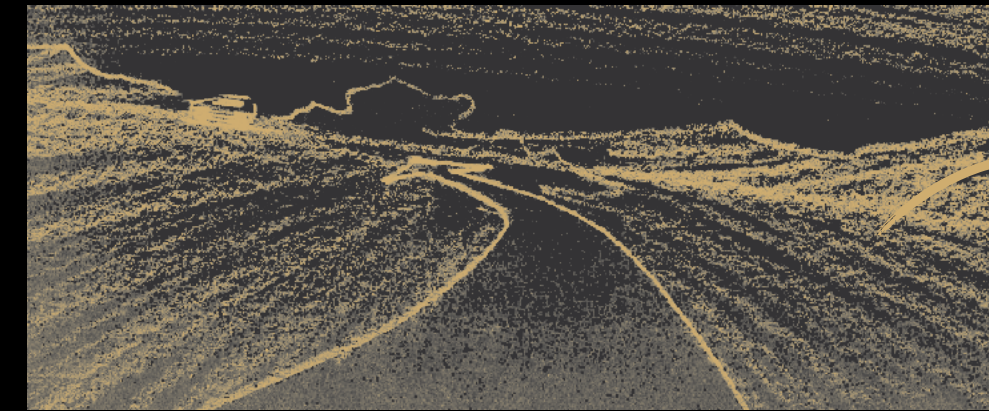

Scene 43
The EARTH drives freely.



Scene 50
A woman's studio — the walls filled with astrophotography works.

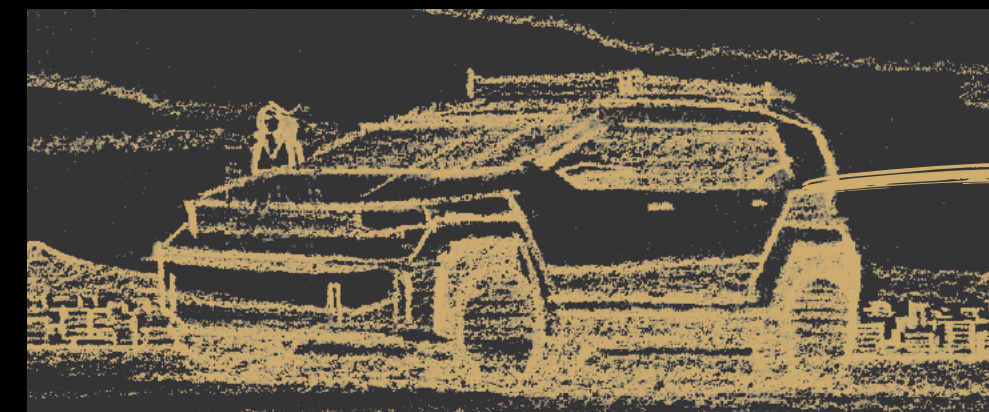

Scene 55
The EARTH is fully revealed.



Scene 58
A man opens the VENUS's door.

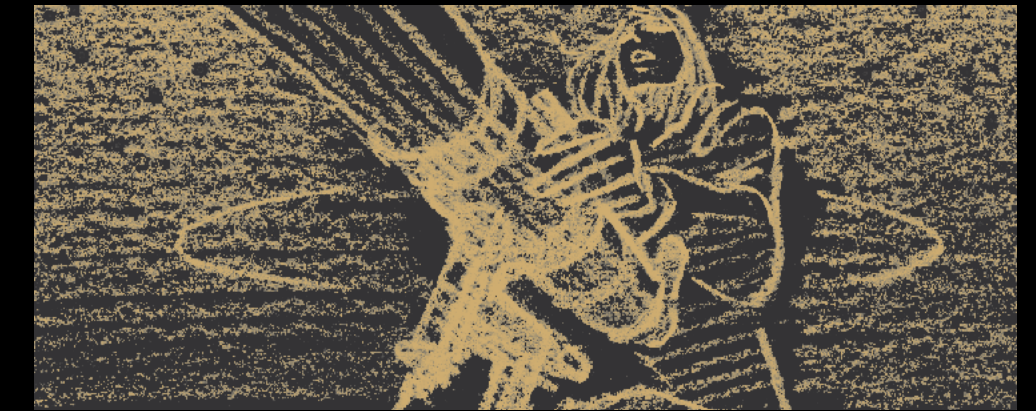

Scene 45
A woman feels a sense of freedom under a beautiful, star-filled night sky.

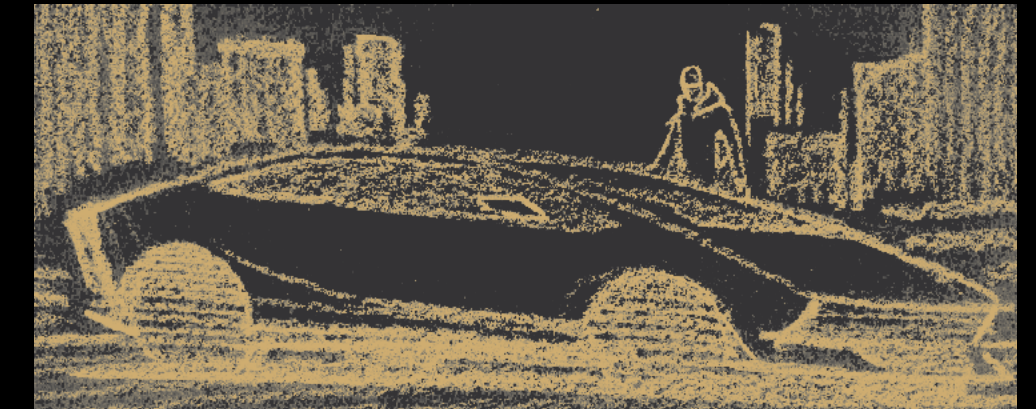

Scene 54
The VENUS is fully revealed.



Scene 56
The woman's eyes gaze at the EARTH.



Scene 60
China, seen from a satellite, appears like a starry sky.



从之前的选史我就坚信过两台车注定不是没落之辈，更是一段与团队一起探索的过程。从创意前期到概念落地这段旅程更像是一场设计闯关，记忆充实。能和大家一起打磨设计，梳理设计语言如何表达，协作完成视频制作，尽力把团队的构思清晰传达给大家，感谢各位伙伴的并肩攻坚，包容磨合，携手攻克难题，让项目有一个圆满的呈现！

From the moment we chose the concept, I was sure these two cars would stand out and bring fresh energy to the "boring" car design industry. From the initial creative brainstorm to the final completion of the concept cars, this journey was like a fun design challenge-busy but joyful. In charge of design strategy, I refined our design language, produced videos, and tried to clearly convey the team's creative ideas in an easy-to-understand way. I'm grateful to worked with outstanding designers, turning scattered ideas into complete plans with passion and perseverance. Thanks to every team member, we overcoming all those difficult challenges together.

Hyundai Design China
William Zhang

经历了整个内饰的设计之后，才切身的体会到设计不仅仅是源于表面的，而是由内而外系统性的探索。这是为整个车赋予灵魂的基石，让“VENUS”散发出的魅力更加有温度，也让我对内饰设计的理解更加深刻。感谢我的领导和各个团队给予的支持，“VENUS”是属于我们共同努力完成的结果。

After going through the entire interior design process, I have truly realized that design is not just about superficial aesthetics, but a systematic exploration from the inside out. This is the foundation of endowing the whole vehicle with a soul, making the charm of "VENUS" more warm and heartfelt. It has also deepened my understanding of interior design. I am truly grateful to my leaders and all teams for their support. "VENUS" is the achievement of our joint efforts.

Hyundai Design China
Mingzhi Tang



EARTH COCEPT是我作为设计师而言的一次难忘设计经历，从一次一次的脑洞大开，做前所未有的设计尝试，到执行落地，每个环节都充满未知，挑战，并有趣。感谢团队的每个成员让我们可以互相学习和成长。

The Earth concept project has been an unforgettable experience for me as a designer. From constantly thinking outside the box and making unprecedented attempts to the final execution, every step was filled with unknowns, challenges, and excitement. I am grateful to every member of the team for allowing us to learn and grow together.

Hyundai Design China
Yuanhao Zhao



我们以 Venus 为灵感，将宝石晶体、光影与精密结构融入内饰设计，具体的优雅线条、刚体的棱角肌理，既是自然之美亦是设计秩序。我们始终相信，浪漫的主题需要理性的结构支撑，流动的光线需要严谨的形式承载，在斟酌的每处线条与光影时，专注于美学表达，更严谨去做设计，让座舱不止于视觉，更成为可感知、可沉浸喜爱的空间。

Drawing inspiration from Venus, we integrate gemstone crystals, light and shadow, and precise structures into the interior design. The elegant halo of the planet and the angular texture of crystals represent both natural beauty and design order. We firmly believe that romantic themes require rational structural support, and flowing light demands rigorous form. When refining every line and shadow, we stay true to aesthetic expression while upholding strict design principles. The cabin is more than visual appeal-it is a perceptible, immersive, and enjoyable space.

Hyundai Design China
Jinyao Li

参与这次概念车项目，对我来说，更像一段与团队一起探索的过程。从最初有点模糊的想法，到一次次讨论和尝试中慢慢变的清晰。设计好像是自己一点点长出来的，这个过程中有许多不同的声音与灵感，也让团队之间默契变的更强。特别感谢设计领导一直以来的支持与信任，也感谢每一位伙伴的同心协力。

“地球”这个有趣的概念，不仅让设计变得更丰富，也让我看到了团队更多的可能性。

Working on this concept car felt like a shared exploration. What started as a loose idea slowly became clearer through conversations, sketches, and experiments. Over time, the design began to find its own language and character. I'm very grateful for the support and trust from our design leadership, and for the dedication and collaboration from the whole team. This concept was not only an interesting project, it also revealed new possibilities for how our team can think, create, and grow together.

Hyundai Design China
Yungcheng Huang



我们不是完成了一个普通的项目，这完全是一次艰难而大胆的自我突破。我自信我们的作品将开创一种全新的设计风尚。

I think this is not the end of a project. It is an extremely hard challenge and a self-breakthrough. I believe that these works will completely create a new trend.

Hyundai Design China
Jiali Wen



在 Venus 和 Earth 项目开发过程中，感谢 Changhyeon, Jeongmee, Qingjun 在项目过程中给予的帮助，从方案到各种创新材料的研发，再到最终产品的呈现，还在与设计团队团队合作，把大家共同努力下，最终让产品变得愈加完美。

During the development of VENUS and EARTH, I wish to express my sincere gratitude to Changhyeon, Jeongmee and Qingjun for their invaluable support throughout the entire process, from initial proposal conceptualization and the development of various innovative materials to the final product realization. Additionally, our seamless collaboration with the design team has been instrumental; it is through the joint efforts of all parties involved that the final product has been refined to near perfection.

Hyundai Design China
Huiliang Tang



由衷感谢领导们始终的信任包容和团队伙伴们默契的配合。很荣幸能和大家并肩努力让这辆奇车顺利呈现在大众眼中。从创意到模型再到成品，过程中我们仿佛在“规则的赛道上寻找最优解”。成果不仅是一辆车，更是路上积累的默契与成长。

I sincerely appreciate the leaders unwavering trust and the team members' seamless collaboration. It's an honor to work side by side with everyone to bring this vehicle to public attention. From the initial concept to the digital model and final product, we approached it as "finding the optimal solution within defined parameters." The outcome isn't just a car-it's the synergy and growth forged through our journey.

Hyundai Design China
Xuezheng Wang



作为VENUS的外饰设计师，我由衷欣喜，公司愿意将这份不逐流，不从众的设计方案正式推向中国市场。感谢这份对设计的尊重，也敬佩这份敢于突破的勇气。创作路上，每一处细节都历经取舍与斟酌，我们于繁杂中沉淀，最终删繁就简，守一份干净与纯粹。愿这份坚持与诚意能被你喜欢。

As an exterior designer of VENUS, I am truly delighted that the company has decided to officially introduce this unconventional, non-conformist design to the Chinese market. I am grateful for this respect for design and admire the courage to break new ground. Every detail along the creative journey has been shaped by careful consideration and deliberate choices. Through complexity we sought clarity-stripping away the unnecessary to preserve what is clean and pure. We hope this dedication and sincerity resonates with you.

Hyundai Design China
Dehui Yang

‘做一辆概念车是一件很酷的事情，尤其这还是我超爱的概念与外饰，我能为其赋予内容，设计甚至角色灵魂，没有比这更酷的事儿！’ Earth内饰是一个小型生态圈，是全景动照、顾乘客的舒适圈——这里提供氧气、温度、稳定、柔软。希望看到 Earth的大象，在发出 WOW 的赞叹后，也会对这特别内饰作酸会心一笑。最后非常感谢这一路来领导的支持与指导，同事的帮助与付出，这是一趟如此了不起的旅途。



Creating a concept car is an incredibly cool experience - especially when it has awesome concept & exterior design, something I'm truly passionate about. It's more than just design; it's about giving it meaning, character, and even a soul. Nothing beats that." Earth Interior is like a small ecosystem — a cozy zone that actively takes care of its passengers by offering oxygen, stable temperatures, and a soft, calming environment. I hope that when people see Earth, after the first "wow," they'll also enjoy a smile inspired by its unique interior experience. Finally, a huge thank you to my leaders for their support and guidance, and to my colleagues for their help and dedication along the way — it's truly been an incredible journey—

Hyundai Design China
Ruien Hu

参与本次展车项目，是一次宝贵的跨部门协作体验。我与南楠、烟台的色彩设计师们共同，将核心概念设计深度融合色彩与材料开发，大量的可以回收和生物基材料运用，传递了人与自然和谐共生的理念。这既是对新材料应用的积极探索，也期待为谋创造更多可能。希望大家都会喜欢“Venus”与“Earth”。

Taking part in this show car project has been such a great cross-departmental experience for me. I worked closely with color designers from Namyang and Yantai, weaving our core design concept right into the color and material development. By using lots of recyclable and bio-based materials, we wanted to share the idea of living in harmony with nature. It's also been an exciting exploration into new material uses, and we're hoping to open up more possibilities for the future. I really hope you'll love "Venus" and "Earth".

Hyundai Design China
Qinglun Li



感谢团队的辛勤付出，我们每个人都付出了巨大的努力。从图纸到现实，每一步都充满了挑战。当设计逐渐清晰，我最终意识到，最珍贵的东西并非是一项完美的落地，而是团队在未知中不断探索的勇气。我们都是打破常规的人。

Thanks to the team for your hard work-every one of us has made tremendous efforts. From sketches to reality, every step has been filled with challenges. As the design gradually took shape, I came to realize that the most valuable thing is not the flawless final result, but the courage of the team to keep exploring the unknown. We are the ones who break the mold.

Hyundai Design China
Yi Guo



这是一段探索与协作的旅程。最初的火花在碰撞中成形，不同角色间的默契配合，让设计得以完整落地。感谢一路同行的伙伴，让深夜有人并肩，让每一次归零之后，依然选择相信。故事从VENUS和EARTH开始，但远未结束。期待下一颗行星，与我们相遇。

This has been a journey of exploration and collaboration. From the initial spark to the final form, ideas took shape through the clash of perspectives, and the synergy of diverse roles brought the design to life. Deeply grateful to every partner who walked alongside us-for sharing late nights and choosing to believe, again and again. The story begins with VENUS and EARTH, yet it is far from over. I look forward to the next planet, where our paths will cross again.

Hyundai Design China
Yawen Zhang

参与Venus项目，让我对公司的设计理念有了更深刻的理解与体会。以线条为诗，用曲面为形，在数字世界里雕琢每一寸光影流动，让硬朗的车身藏起温柔韵律。我们把Venus的优雅，转化为曲线进阶的严谨；将艺术灵感，落地为可量产的精致。不只是塑造形态，更是赋予车辆灵魂与温度，让机械之美，遇见永恒的浪漫。

Working on the Venus project has deepened my understanding of the company's design philosophy. We craft poetry in lines and sculpt forms with surfaces, refining every flow of light and shadow in the digital realm, letting bold bodywork hold gentle rhythm. We translate Venus's elegance into rigorous continuity of curvature, and turn artistic inspiration into production-ready refinement. It is more than shaping form-it is breathing soul and warmth into the vehicle, letting mechanical beauty meet timeless romance.

Hyundai Design China
Qingli Chen

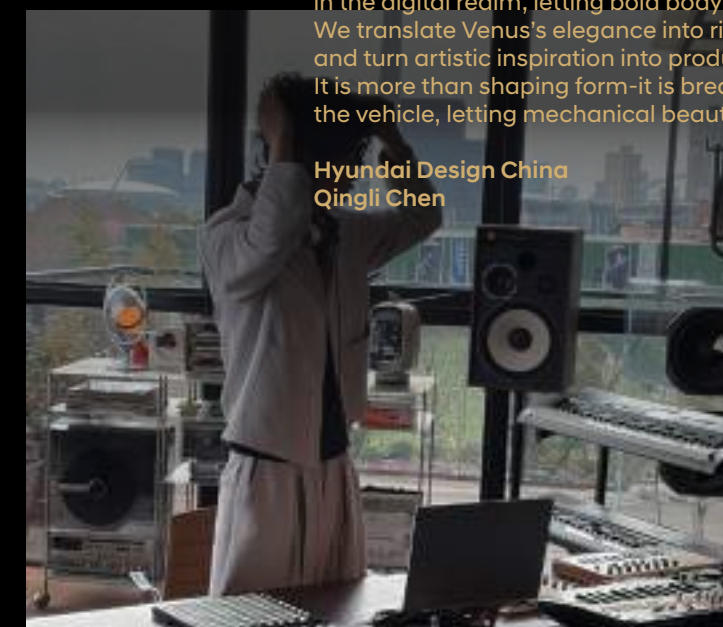

几年前在车展上，我被现代展台上那辆概念车简洁而独特的设计吸引，在众多相似的产品中，它留下了非常清晰的记忆。几年后能够加入现代，并参与到这次概念车设计，对我来说是一件非常难得的经历。感谢在这个项目中帮助我的同事，让我也像一块原石，在不断打磨中慢慢成长。

A few years ago at an auto show, I was drawn to a concept car at the Hyundai booth. Its design felt simple and pure, and it stood out clearly among many similar products. A few years later, being able to join Hyundai and take part in this concept car project has been a very special experience for me. I'm grateful to my colleagues who supported me along the way. Their help allowed me to grow gradually, like a rough stone being shaped and polished.

Hyundai Design China
Lingwei Deng

我很荣幸与激动，作为一名战略设计师参与了这款具有里程碑意义的车型设计。在这个数据爆炸的市场环境里，我们有十足的信心，通过这款展现 Hyundai Design 独特创新新性的产品，并构建未来中国消费者向往的、现代真正的品牌形象重塑与品牌价值跃迁。也感谢整个设计团队的协作与不懈努力，从用户洞察到方案落地，各个环节都凝聚团队对于中国用户深层需求的理解与洞察。

I feel deeply honored and thrilled to have participated extensively in the design of this epoch-making project as a Strategic Designer. In this spec-driven hyper-competitive market environment, we have full confidence that, through this product showcasing the unique innovation of Hyundai Design, we will build a sense of aspiration for future Chinese consumers, achieving a true reshaping of brand image and a leap in brand value. I would like to express my gratitude to the entire design team for their multidimensional collaboration and unremitting efforts; from user insights to solution implementation, every stage embodies the team's understanding and response to the deep needs of Chinese users.

Hyundai Design China
Junyang Shen



행성을 원리로 탄생한 중국 전용 IONIQ,
그런 그 차상을 광활한 해시 '우주'를 공간으로 구현해사했된 과학이 기억에 남는다.
우주적 상상력을 공간의 틀에, 차상이 가장 흥미는 장면을 만들어주며
복합 경험을 만들고, 수많은 의미를 거듭했던 과학이 신명나게 기억이 남아 있다.

The process of bringing to life a China-exclusive IONIQ inspired by planetary forms, and envisioning an entire "universe" centered around the vehicle, remains vividly memorable. Translating cosmic imagination into spatial expression—while crafting moments where the vehicle could truly stand out—meant building mock-ups and engaging in countless discussions, a journey that still resonates clearly today.

Spacedesign 1 Team
Seonug Youn



변화가 많은 중국 시장 속에서도 아이오닉 브랜드로 새로운 도전을 이어가는 현대차의 프로젝트에 참여할수 있어 매우 뜻깊은 시간이었습니다. 특히 대형 시그처북 디자인은 개인적으로도 도전적인 과제였는데, 만족스러운 결과물을 완성하게 되어 큰 보람을 느낍니다.

아이오닉의 여정이 중국 시장에서 의미있게 이어지길 진심으로 기대합니다. Open your universe, IONIQ!

It was a meaningful opportunity to contribute to Hyundai Motor Company's project, as the brand continues to push boundaries in China's ever-changing market. The large-format book design was a personal challenge, and completing it with a satisfying result made the experience especially rewarding. I look forward to seeing IONIQ's journey continue to resonate in the Chinese market. Open your universe, IONIQ!

Brand Experience Design Team
Seohee Park

중국 시장 내 현대의 새로운 모습을 IONIQ이 전달할 수 있기를 희망합니다. 이 차들을 통해 각자만의 세계를 열기를!!

I hope that IONIQ can convey a fresh new image of Hyundai within the Chinese market. May these cars help everyone open up their own unique universe!!

Marketing Strategy Team
Jay Kim



중국의 엄청난 스케일과 우주의 신비함, EARTH, VENUS Concept의 유려함까지 짧은 내용의 플랫폼 안에 담아내기위해 많은 고민을 거뒀습니다. 이번 프로젝트가 현대차의 화려한 중국 정복을 알리는 성공적인 첫 단추가 되었길 바랍니다!

We put a great deal of thought into capturing China's overwhelming scale, the mystery of the cosmos, and the elegance of the EARTH VENUS Concept within the brief format of short-form content! I hope this project serves as a successful first step in announcing Hyundai's spectacular return to the Chinese market!

Digital Communication Team
Julia Lee

중국시장만을 바라보며 모두가 힘을 모아진행해 온 똑같은 프로젝트에 함께할 수 있어 영광이었습니다.
프로젝트의 성공을 위해 바쁘게 달리는 동안 우리는 각기 다른곳에 있었지만, 그 안에 담긴 진심은 하나로 모였다고 생각합니다. 한 마음으로 천천히 도움과신 많은 담당자분께 깊이 감사드립니다.
중국 고객분들도 현대자동차의 이러한 진심을 꼭! 알아나 주셨으면 하는 마음입니다.
IONIQ이 자신만의 채도로 삶을 산이자는 모든 이들과 함께하기를 바라며,
저 또한 항상 응원하는 마음으로 지켜보겠습니다.
谢谢

It has been a great honor to be part of this meaningful project, where we all came together with a singular focus on the Chinese market. Although we may have been in different locations while racing toward the project's success, I believe our hearts and sincerity were united as one. I would like to express my deepest gratitude to everyone who kindly offered their support with a shared vision. I truly hope that our Chinese customers will also recognize and feel Hyundai Motor's genuine sincerity. Just as the IONIQ accompanies those who live life in their own orbits, I will always be watching and cheering for you all.

Marketing Communication Team
Nakyoung Lee





解锁你的宇宙, IONIQ(艾尼氪)

以你为序 宇宙新生

Open your universe, IONIQ

The beginning of a new universe,
centered on you.

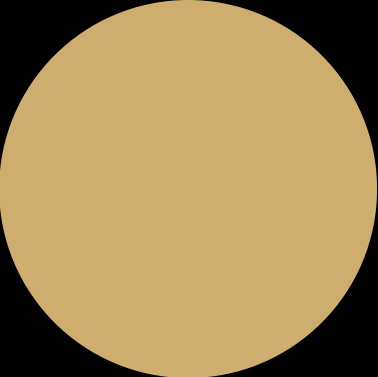

IONIQ